

**SWAMI DAYANANDA COLLEGE OF ARTS & SCIENCE,  
MANJAKKUDI – 612 610  
PG DEPARTMENT OF CHEMISTRY**

**UNIT I – ELECTROCHEMISTRY**

**Dr.G.Marimuthu**

**Assistant Professor & Research Supervisor**

## **1.1 INTRODUCTION**

What is electrochemistry?

**Electrochemistry** is a branch within the field of chemistry which deals with the **study of chemical reactions that involves electricity**. It involves the **inter conversion of electrical energy and chemical energy**. The inter conversion of chemical energy and electricity occurs when electron-transfer reaction occurs (i.e) oxidation-reduction or redox reactions. This reaction results in the **generation of an electric current** (electricity) due to chemical changes or electricity is used to **produce chemical changes**. Therefore, this field of chemistry is often called **ELECTROCHEMISTRY**.

*Electrochemical processes* are oxidation-reduction reactions in which the energy released by a spontaneous reaction is converted to electricity (or) electrical energy is used to cause a non-spontaneous reaction to occur.

## **STUDY OF ELECTROCHEMISTRY**

- ☞ Electrochemistry is also used in scientific laboratories, for processing and analyzing a range of materials.
- ☞ It is also used in processes such as electroplating, in which the property of electro deposition is harnessed and in the operation of batteries, which utilize a chemical reaction to generate electrical energy.
- ☞ Another example of a natural electrochemical reaction is corrosion, especially iron oxidation, which is better known as "rust".

### **1.1.1 CONDUCTORS**

A material that “conducts” the electric current or flow of electrons easily is called a **conductor**. In Conductors the outer electrons of the atoms are loosely bound and free to move through the material.

**Examples:** All metals, fused salts, aqueous solutions of acids, bases, etc.

### **1.1.2. INSULATORS**

**Insulators** are materials that “don’t conduct” electric current. They do not let electrons flow very easily from one atom to another. Insulators are materials whose atoms have tightly bound electrons.

**Examples:** Glass, plastic, rubber, air, and wood.

### **1.1.3 TYPES OF CONDUCTORS**

#### **METALLIC CONDUCTORS (OR) ELECTRONIC CONDUCTORS**

Metallic conductors are solid substances, which conduct electric current due to the movement of electrons from one end to another end. The conduction decreases with increase of temperature.

**Examples:** All metals, graphite

#### **ELECTROLYTIC CONDUCTORS**

Electrolytic conductors conduct electric current due to the movement of ions in solution or in fused state. The conduction increases with increase of temperature.

**Examples:** Acids, bases & electrovalent compounds

#### **TYPES OF ELECTROLYTIC CONDUCTORS**

##### **STRONG ELECTROLYTES**

Substances which give highly conducting solutions when dissolved in water because they are completely dissociated into ions (ionize completely) are called as strong electrolytes.

**Examples:** HCl, NaCl, Na<sub>2</sub>SO<sub>4</sub>, KNO<sub>3</sub>, H<sub>2</sub>SO<sub>4</sub>, NH<sub>4</sub>Cl etc.

##### **WEAK ELECTROLYTES**

Substances, which give poorly conducting solutions when dissolved in water because they are ionized to a very small extent (ionize only partially) are called as weak electrolytes.

**Examples:**  $\text{NH}_3$ ,  $\text{CH}_3\text{COOH}$ ,  $\text{H}_2\text{CO}_3$ , organic bases etc.

## NON ELECTROLYTES

Not all substances that dissolve in water are electrolytes. Substances which do not ionize at any dilutions are known as non electrolytes.

For **example**, Sugar dissolves readily in water, but remains in the water as molecules, not as ions. Sugar is classified as a non-electrolyte.

### 1.1.4. DIFFERENCES BETWEEN METTALIC CONDUCTION AND ELECTROLYTIC CONDUCTION

| S.No. | Metallic Conduction                                 | Electrolytic Conduction                                  |
|-------|---|--|
| 1.    | It involves the flow of electrons in the conductor. | It involves the movement of ions in a solution.          |
| 2.    | It does not involve any transfer of matter.         | It involves transfer of electrolyte in the form of ions. |
| 3.    | Conduction decreases with increase in temperature.  | Conduction increases with increase in temperature.       |
| 4.    | No change in chemical properties of the conductor.  | Chemical reactions occur at the two electrodes.          |

### 1.1.5 CELL TERMINOLOGY

#### ELECTRIC CURRENT:

Electric current means, a flow of electric charge (a phenomenon) or the rate of flow of electric charge (a quantity).

This flowing electric charge is carried by moving electrons, in a conductor such as wire and in an electrolyte, it is carried by ions.

The SI unit for measuring the rate of flow of electric charge is the ampere. Electric current is measured using an ammeter.

#### ELECTRODE:

❖ Electrodes may be wires, plates or rods.

- ❖ An **electrode** is an electrical conductor used to make contact with a nonmetallic part of a circuit (e.g. a semiconductor, an electrolyte or a vacuum).

### **ANODE:**

- ❖ An anode is an electrode at which current leaves the cell and oxidation takes place.
- ❖ It is the positive electrode in an electrolytic cell, while it is the negative electrode in a galvanic cell.

### **CATHODE:**

- ❖ A cathode as a negative electrode at which electrons enters the cell and reduction takes place.
- ❖ It is the negative electrode in an electrolytic cell, while it is the positive electrode in a galvanic cell.

### **ELECTROLYTE:**

- ❖ An electrolyte is a substance which dissociates free ions when dissolved (or molten), to produce an electrically conductive medium. Electrolytes are also known as **ionic solutes**.
- ❖ Electrolytes generally exist as acids, bases or salts.
- ❖ If a high proportion of the dissolved solute dissociates to form ions, the solution is strong; if most of the dissolved solute remains un-ionised, the solution is weak.

### **ANODE COMPARTMENT:**

- ❖ Anode compartment is the compartment of the cell in which oxidation- half reaction occurs. It contains the anode.

### **CATHODE COMPARTMENT:**

- ❖ Cathode compartment is the compartment of the cell in which reduction- half reaction occurs. It contains the cathode.

### **HALF CELL:**

- ❖ Half cell is a part of a cell. It consists of a single electrode, generally a metal, immersed in a container filled with a suitable electrolyte.
- ❖ In a half cell either oxidation or reduction can occur. If oxidation occurs at the electrode that is called oxidation half cell. If reduction occurs at the electrode that is called reduction half cell.

## CELL:

❖ Cell is a device consisting of two half cell. The two half cells are connected through one wire.

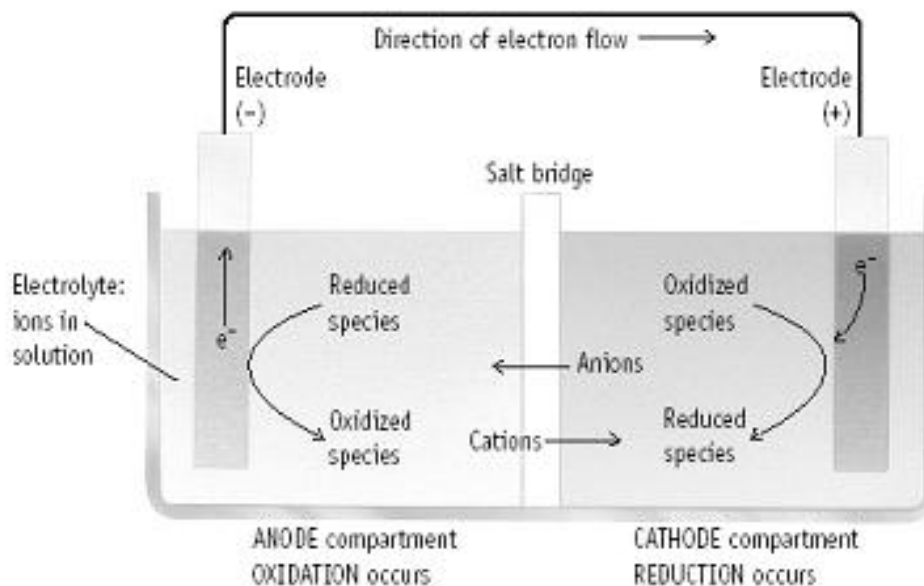


Fig. 1.1 Electrochemical cell

### 1.1.6 TERMINOLOGY FOR REDOX REACTIONS

**OXIDATION**— loss of electron(s) by a species; increase in oxidation number; increase in oxygen.

**REDUCTION**— gain of electron(s); decrease in oxidation number; decrease in oxygen; increase in hydrogen.

**OXIDIZING AGENT**— electron acceptor; species is reduced.

**REDUCING AGENT**— electron donor; species is oxidized.

### 1.2 TYPES OF CELLS

☞ ELECTROLYTIC CELLS

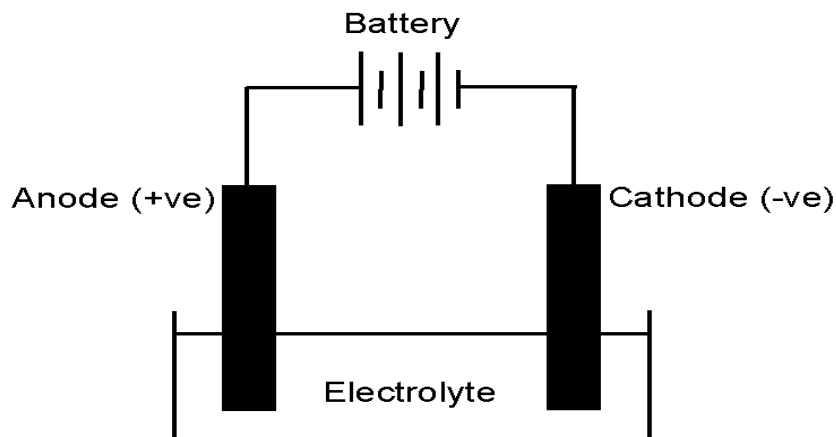
☞ ELECTROCHEMICAL CELL (or) VOLTAIC CELL (or) GALVANIC CELLS

### 1.3 ELECTROLYTIC CELL

“Electrolytic cell is a device in which a non-spontaneous redox reaction is used to convert electrical energy into chemical energy”.

The anode of an electrolytic cell is positive (cathode is negative). Anions are attracted towards the anode where they undergo oxidation. Electrons flow from the anode to the cathode where cations undergo reduction.

**Example:** Electrolysis, electroplating, etc.



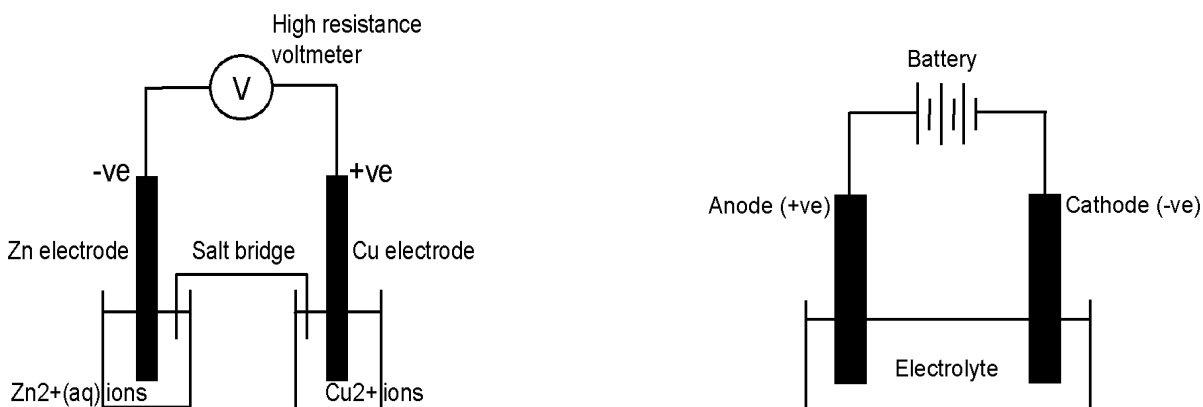
**Fig. 1.2 Electrolytic cell**

## 1.4 ELECTROCHEMICAL CELL

“Electrochemical cell is a device in which a spontaneous redox reaction is used to convert chemical energy into electrical energy” (i.e.) electricity can be obtained with the help of oxidation and reduction reaction”.

The anode of an electrochemical cell is negative (cathode is positive). Anions are attracted towards the anode where they undergo oxidation. Electrons flow from the anode to the cathode where cations undergo reduction.

**Example:** Daniel cell

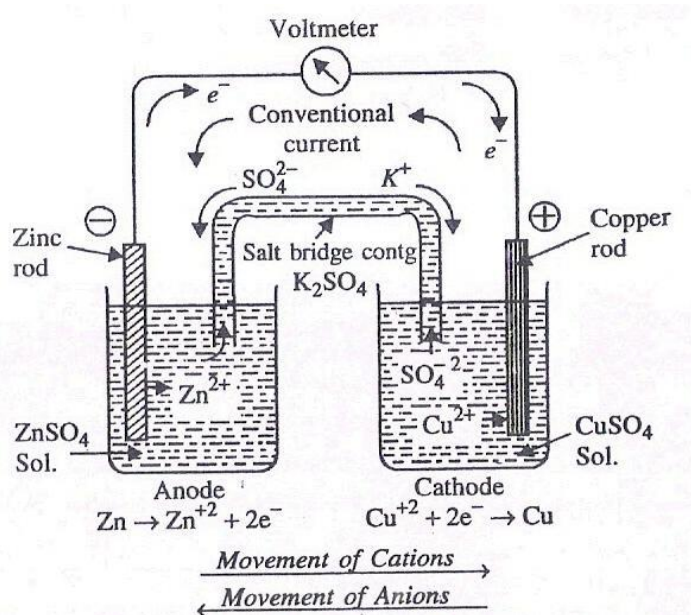


**Fig. 1.3 Voltaic Cell vs Electrolytic Cell**

### 1.4.1 CONSTRUCTION OF ELECTROCHEMICAL CELL

An electrochemical cell is a device used to convert chemical energy of an indirect redox reaction into electrical energy. This is also called Voltaic cell or a Galvanic cell.

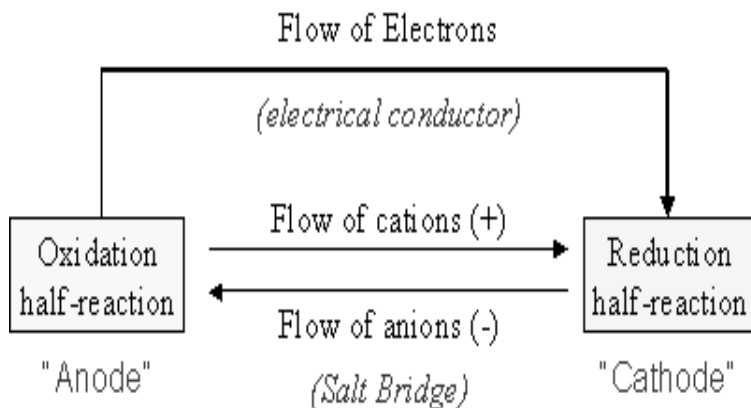
A common galvanic cell is the **Daniel cell**.



**Fig. 1.4 Daniel Cell**

Daniel cell consists of a zinc electrode dipped in 1 M ZnSO<sub>4</sub> solution and a copper electrode dipped in 1 M CuSO<sub>4</sub> solution. Each electrode is known as a half cell. The two solutions are inter connected by a salt bridge and the two electrodes are connected by a wire through the voltmeter.

An inverted U tube containing concentrated solutions of inert electrolytes such as KCl, KNO<sub>3</sub> etc., connects the two solutions. This U tube is called as salt bridge, as it acts like a bridge connecting the two half cells. The two openings of the U tube are plugged with porous materials like glass wool or cotton.



The overall reaction is:

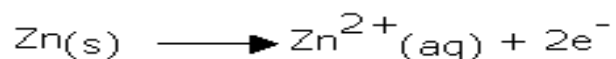


## REACTIONS OCCURRING IN THE CELL:

### AT ANODE:

Oxidation takes place in the zinc electrode by the liberation of electrons, so this electrode is called negative electrode or anode.

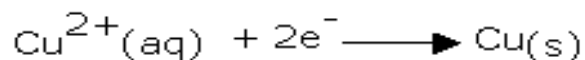
Zinc metal is oxidized to  $\text{Zn}^{2+}$  ions and goes into the solution during the reaction.



### AT CATHODE:

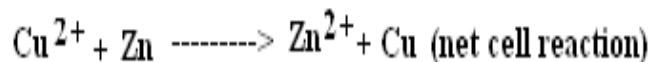
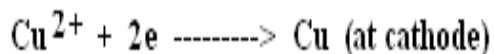
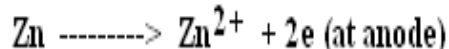
Reduction takes place in the copper electrode by the acceptance of electrons, so this electrode is called the positive electrode or cathode.

The electrons released at the electrode travel through the external circuit to the Cu electrode. These electrons are accepted by  $\text{Cu}^{2+}$  ions of  $\text{CuSO}_4$  solution. Thus the  $\text{Cu}^{2+}$  ions are reduced to metallic copper, which get deposited on the copper electrode.





## OVERALL CELL REACTION:



Thus, indirect redox reaction leads to the production of electrical energy.

### 1.4.2 SALT BRIDGE

A salt bridge is a low resistance device, which establishes an electrical contact between two electrolytes not in direct contact. It is usually an inverted U-tube filled with concentrated solution of inert electrolytes. An inert electrolyte is one whose ions are neither involved in any electrochemical change nor do they react chemically with the electrolytes in the two half-cells. The salt bridge consists of a glass U-tube filled with KCl containing Agar-Agar paste, which sets into a gel. The ends of the U-tube are plugged with cotton wool as to minimize diffusion effects.

Commonly used salts are, KCl,  $\text{NH}_4\text{NO}_3$ ,  $\text{KNO}_3$ , or  $\text{K}_2\text{SO}_4$ .

### FUNCTIONS OF SALT BRIDGE

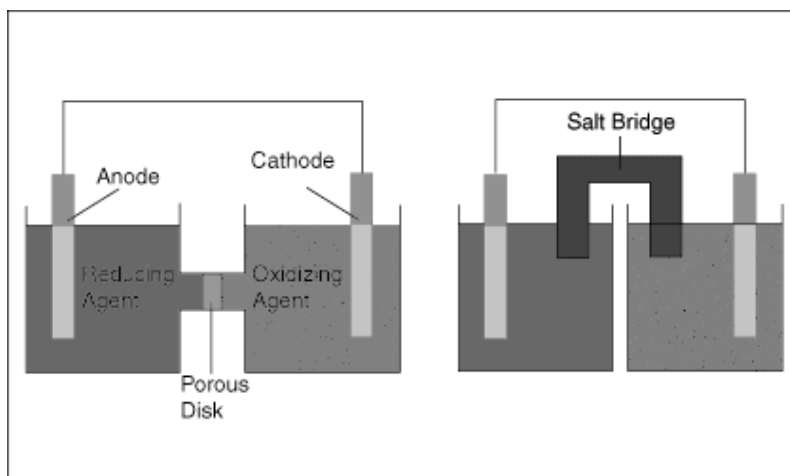
- The salt bridge connects the solutions of two half-cells and completes the cell circuit. (or) It provides the electrical continuity between the two half cells.
- The salt bridge prevents the physical diffusion of the electrolytes from one half-cell to the other.
- It prevents liquid-liquid junction-potential, i.e., the potential difference which arises between two solutions when in contact with each other.

### Representation of salt bridge

A broken vertical line or two parallel vertical lines in a cell representation indicates the salt bridge.



Salt bridge can be replaced by a porous partition which allows the migration of ions without allowing the solutions to intermix.



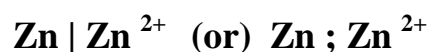
**Fig 1.5 Representation of salt bridge**

### 1.4.3 REPRESENTATION OF ELECTROCHEMICAL CELL

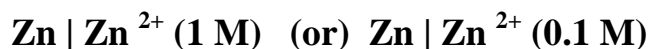
The following universally accepted conventions are followed in representing an electrochemical cell:

#### **Anode / Electrolyte I (conc) // Electrolyte II (conc) / Cathode**

- The anode (negative electrode) is written on the left hand side and cathode (positive electrode) on the right hand side.
- A vertical line or semicolon (;) indicates a contact between two phases. The anode of the cell is represented by writing metal first and then the metal ion present in the electrolytic solution. Both are separated by a vertical line or a semicolon. For example,



The molar concentration of the solution is written in brackets after the formula of the ion. For example,



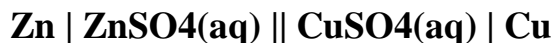
- The cathode of the cell is represented by writing the cation of the electrolyte first and then metal. Both are separated by a vertical line or semicolon. For example,



- The salt bridge which separates the two half-cells is indicated by two parallel vertical lines.

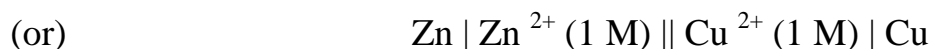


Using the above representation, the Daniel cell can be represented as follows:



Anode      Salt bridge      Cathode

Oxidation half-cell      Reduction half-cell



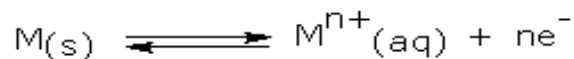
#### 1.4.4 DIFFERENCES BETWEEN ELECTROLYTIC CELL AND ELECTROCHEMICAL CELL:

| S.No. | Electrolytic cell  | Electrochemical cell  |
|-------|--|---|
| 1.    | Electrical energy is used to bring about the chemical change.  | Chemical energy is utilized to get electrical energy.   |
| 2.    | The anode is positively charged w.r.t. cathode. The anions migrate to this electrode and get oxidized.       | The anode is negatively charged w.r.t. cathode and oxidation reaction occurs. The electrons are released from this electrode. |
| 3.    | The cathode is negatively charged w.r.t. anode. The cations migrate to this cathode and get reduced.         | The cathode is positively charged w.r.t. anode. The cations get reduced by the electrons coming from the anode.               |
| 4.    | The electrons flow towards cathode and come out through anode.   | When the electrodes are connected, the electrons move from anode to cathode in the external circuit.                          |
| 5.    | Amount of electricity passed during electrolysis is measured by coulometer.                                  | The emf produced by the cell is measured by potentiometer.  |
| 6.    | The extent of chemical reaction taking place at the electrodes is governed by Faraday's law of electrolysis. | The emf of the cell depends on the concentration of the electrolytes and the chemical nature of the electrodes.               |
| 7.    | Electrolysis is a good example for electrolytic cell.  | Galvanic cell is a good example for electrochemical cell.   |

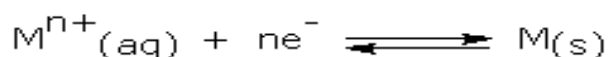
## 1.5 ELECTRODE POTENTIAL

When a metal M is placed in a solution of its own salt, the processes that can occur at the electrodes are:

- ➔ A metal atom on the electrode M may lose 'n' electrons and enter the solution as  $M^{n+}$ , (i.e., the metal atom is oxidized).



- ➔ A metal ion  $M^{n+}$  collides with the electrode, gains 'n' electrons and gets converted into a metal atom M (i.e., the metal ion is reduced).

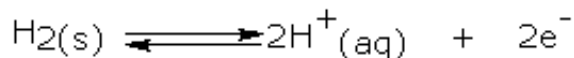
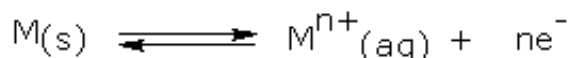


So, an electrode develops a charge depending upon the nature of the process, which is favoured at the electrode. Due to separation of charges between the electrode and the solution, an electrical potential is set up between metal electrode and its solution. The electrical potential difference between the metal and its solution is known as **electrode potential** (or half-cell potential). Thus, *the electrode potential is a measure of tendency of an electrode in a half-cell to gain or lose electrons.*

Electrode potentials are denoted by the letter **E** and are of two types:

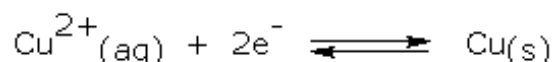
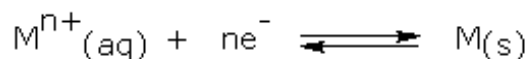
### ➤ Oxidation Potential

The tendency of an electrode to lose electrons or to get oxidized is called its oxidation potential.



### ➤ Reduction Potential

The tendency of an electrode to gain electrons or to get reduced is called its reduction potential.

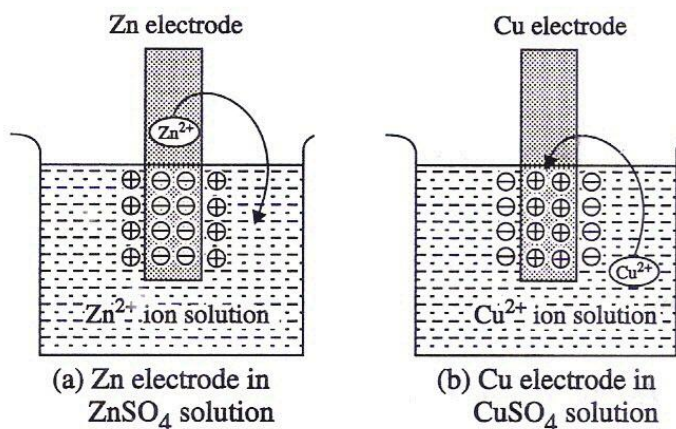


It is evident that the oxidation potential is the reverse of reduction potential. For example, reduction potential of Zn is - 0.76 a volt, its oxidation potential is + 0.76 volts.

According to the present convention, the half-cell reactions are always written as reduction half reactions and their potentials are represented as reduction potentials.

## EXPLANATION OF ELECTRODE POTENTIAL

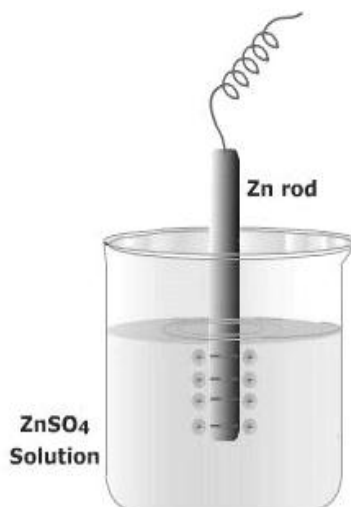
When a metal is placed in a solution of its own salt, the metal acquires either a positive or negative charge with respect to the solution. On account of this, a definite potential difference is developed between the metal and the solution. This potential difference is called **electrode potential**.



**Fig. 1.6 Electrode Potential**

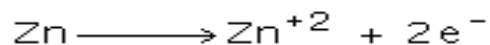
**CASE 1:** When positive ions pass into solution, it leaves behind valence electrons on the metal itself. Due to this the metal gets negative charge. The negative charge developed on the metal attracts positive metal ions from the solution and a positive layer is formed around the negatively charged electrode (metal). This layer is called Helmholtz electrical double layer (edl). This edl prevents further passing of positive ions from or to the metal.

A potential difference is set up at the interface of the metal ions and the electrolyte solution. At dynamic equilibrium, the potential difference becomes a constant value which is known as electrode potential of the metal.

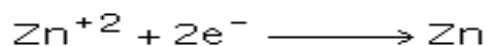


**Example:** Consider a zinc rod being dipped in  $\text{ZnSO}_4$  solution.

The zinc atoms on the surface of the metal within the solution have tendency to release  $\text{Zn}^{+2}$  into solution retaining the electrons on the surface of the metal. This process is called **dissolution**.



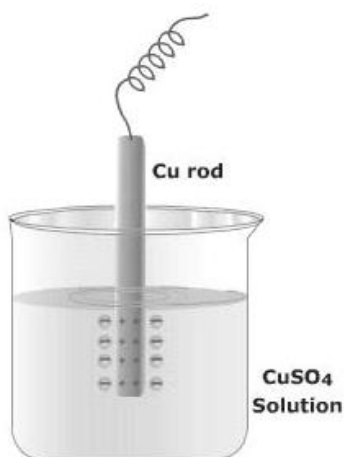
The zinc ions of the solution have a tendency to accept the electrons on the surface of zinc rod to form neutral zinc atoms and get deposited on the zinc rod. This process is called **deposition**.



These two processes will be taking place simultaneously at different rates. In this case, the rate of dissolution is found to be greater than the rate of deposition. Consequently, by the time equilibrium is reached, more of dissolution would have occurred and the solution becomes positively charged. Due to the attractive electrostatic forces, the  $\text{Zn}$  ions accumulate around the  $\text{Zn}$  rod and an electrical double layer of opposite charges is formed. Thus, when a zinc rod is placed in a solution having  $\text{Zn}^{2+}$  ions, it becomes negatively charged with respect to solution and thus a potential difference is set up between zinc rod and the solution. This potential difference is termed the **electrode potential of zinc**.

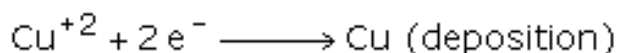
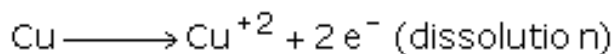
**CASE 2:** When positive metal ions from the solution get deposited over the metal, it attains positive charge due to the accumulation of metal ions on the metal. The positive charge developed on the metal attracts negative ions from the solution and forms an edl close to the

metal. This edl prevents further deposition of the positive ions from the solution and an equilibrium is reached with some definite value of potential difference. This potential difference of edl formed at the interface of the metal and electrolyte is called electrode potential.



**Example:** Consider a copper rod being dipped in  $\text{CuSO}_4$  solution.

Even in this case, both dissolution and deposition will be taking place simultaneously at different rates. Here, the rate of deposition is found to be greater than the rate of dissolution. Hence, by the time the equilibrium is reached, the solution becomes negatively charged while the rod becomes positively charged. Due to the attractive electrostatic forces, the negatively charged  $\text{SO}_4^{2-}$  ions accumulate around the positively charged metal, resulting in the formation of an electrical double layer. Thus, when a copper rod is placed in a solution having  $\text{Cu}^{2+}$  ions, it becomes positively charged with respect to the solution. A potential difference is set up between the copper rod and the solution. The potential difference thus developed is termed as **electrode potential of copper**.



### **Factors affecting electrode potential:**

The rate of the above reaction depends upon,

- The nature of the metal and its ions
- Concentration of the metal ions in the solution and
- Temperature.

## Single Electrode Potential

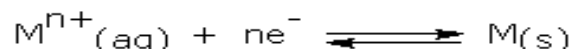
It is the measure of tendency of a metallic electrode to lose or gain electrons, when it is in contact with a solution of its own salt. It is denoted as 'E'.

## Standard Electrode Potential

It is the measure of tendency of a metallic electrode to lose or gain electrons, when it is in contact with a solution of its own salt at 1 molar concentration at 25°C. It is denoted as E°.

### 1.5.1 NERNST EQUATION FOR ELECTRODE POTENTIAL

Consider a general reversible redox reaction,



The electrical energy of a reversible cell can be measured by the free energy decrease (- ΔG) of the reaction taking place in the cell. In the cell, if the reaction involves the transfer of 'n' number of electrons, then 'n' Faraday of electricity will flow. If 'E' is the emf of the cell, then the total electrical energy produced in the cell is

$$-\Delta G = nFE \quad \dots\dots\dots (1)$$

where, - ΔG is the decrease in free energy and 'n' is the number of electrons involved in the cell reaction.

At standard conditions,

$$-\Delta G^{\circ} = nFE^{\circ} \quad \dots\dots\dots (2)$$

where, - ΔG° is the standard free energy change. Standard free energy change is the change in free energy when the concentration of reactants and products are unity.

'E°' is the standard emf of the cell in which the reactants and products are kept at unit molar concentration at 25°C.

For a general reversible redox reaction, according to Vant Hoff isotherm, ΔG and ΔG° are related as,

$$\Delta G = \Delta G^{\circ} + RT \ln K \quad \dots\dots\dots(3)$$

where, K is the equilibrium constant of the reaction. It is defined as the ratio of the concentration of the products to the concentration of the reactants.

$$\Delta G = \Delta G^{\circ} + RT \ln \frac{[\text{Product}]}{[\text{Reactant}]} \quad \dots\dots\dots(4)$$



Substitute the values of  $\Delta G$  and  $\Delta G^{\circ}$  from equation (1) & (2) in equation (4)

$$-nFE = -nFE^{\circ} + RT \ln \frac{[\text{Product}]}{[\text{Reactant}]} \dots\dots\dots(5)$$

Divide equation (5) throughout by  $-nF$

$$E = E^{\circ} - \frac{RT}{nF} \ln \frac{[\text{Product}]}{[\text{Reactant}]} \dots\dots\dots(6)$$

$$E = E^{\circ} - 2.303 \frac{RT}{nF} \log \frac{[\text{Product}]}{[\text{Reactant}]} \dots\dots\dots(7)$$

At 25°C, T = 298 K, R = 8.314 J/K/mole, F = 96,500 coulombs

$$E = E^{\circ} - \frac{0.0591}{n} \log \frac{[\text{Product}]}{[\text{Reactant}]}$$

$$E = E^{\circ} - \frac{0.0591}{n} \log \frac{[M]}{[M^{n+}]} \dots\dots\dots(8)$$

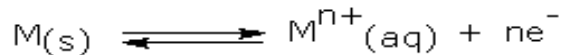
Since the activity of solid metal (i.e)  $[M^{n+}] = 1$  at a given temperature

$$E = E^{\circ} - \frac{0.0591}{n} \log \frac{1}{[M^{n+}]}$$

$$E_{M^{n+}/M} = E^{\circ}_{M^{n+}/M} + \frac{0.0591}{n} \log [M^{n+}] \dots\dots\dots(9)$$

Equation (9) is the Nernst equation for reduction potential of electrode. This equation explains how single electrode potential varies with concentration of electrolyte. ‘E’ will vary depending on the concentration of metal ions present in the solution.

Similarly, the Nernst equation for oxidation potential, (i.e) for the oxidation reaction



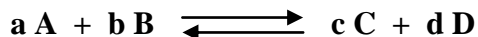
$$E_{M/M^{n+}} = E^{\circ}_{M/M^{n+}} - \frac{0.0591}{n} \log [M^{n+}] \dots\dots\dots(10)$$

### 1.5.2 APPLICATIONS OF NERNST EQUATION

- It is used to calculate the electrode potential (half-cell potential) in a given set of conditions.
- Corrosion tendency of metals in a given set of environmental conditions can be predicted.
- EMF and polarity of electrode in an electrochemical cell is calculated by using Nernst equation.

### 1.5.3 NERNST EQUATION FOR THE EMF OF A COMPLETE CELL

Let us consider a redox reaction (cell reaction) involving transfer of ‘n’ electrons of the type



According to Vant Hoff isotherm

$$\Delta G = \Delta G^{\circ} + RT \ln \frac{[\text{Product}]}{[\text{Reactant}]}$$

$$\Delta G = \Delta G^{\circ} + RT \ln \frac{[C]^c [D]^d}{[A]^a [B]^b}$$

We know that,  $-\Delta G = nFE$  and  $-\Delta G^{\circ} = nFE^{\circ}$

$$-nFE = -nFE^{\circ} + RT \ln \frac{[C]^c [D]^d}{[A]^a [B]^b}$$

Divide the above equation throughout by  $-nF$

$$E = E^{\circ} - \frac{RT}{nF} \ln \frac{[C]^c [D]^d}{[A]^a [B]^b}$$

$$E = E^{\circ} - 2.303 \frac{RT}{nF} \log \frac{[C]^c [D]^d}{[A]^a [B]^b}$$

At 25°C, T = 298 K, R = 8.314 J/K/mole, F = 96,500 coulombs

$$E_{\text{cell}} = E^{\circ}_{\text{cell}} - \frac{0.0591}{n} \log \frac{[C]^c [D]^d}{[A]^a [B]^b}$$

The above equation is the Nernst equation for the EMF of a complete cell. It can be used to calculate EMF of the cell when the concentration of reactants and products of the cell reactions are known.

#### 1.5.4 PROBLEMS BASED ON NERNST EQUATION

**1. What is the potential of a lead electrode that is in contact with a solution of 0.015 M in Pb<sup>2+</sup> ions? Standard electrode potential (E<sup>0</sup>) for Pb → Pb<sup>2+</sup> + 2e<sup>-</sup> is 0.13 volt.**

**Solution :**

Given

Concentration of [Pb<sup>2+</sup>] = 0.015 M and E<sup>0</sup> = + 0.13V

∴ The Nernst equation for oxidation potential of Pb<sup>2+</sup> is

$$E = E^{\circ} - \frac{2.303 RT}{nF} \log [ \text{Pb}^{2+} ]$$

$$E = E^{\circ} - \frac{0.0591}{n} \log [ \text{Pb}^{2+} ]$$

$$E = E^{\circ} - \frac{0.0591}{2} \log [ 0.015 ]$$

$$E = 0.13 - 0.02955 (-1.824) = 0.13 + 0.0539 = 0.184 \text{ V}$$

**Oxidation potential of Pb = 0.184 V**

**2. A zinc rod is placed in 0.1M ZnSO<sub>4</sub> solution at 298K. Write the electrode reaction and calculate the potential of the electrode. (AU 2004)**

**Solution:**

The electrode is  $\text{Zn}^{2+} \mid \text{Zn}$

The electrode reaction is  $\text{Zn}^{2+} + 2e^- \longrightarrow \text{Zn}$

Given

Concentration of  $[\text{Zn}^{2+}] = 0.1 \text{ M}$  and  $E^\circ_{\text{Zn}^{2+}/\text{Zn}} = -0.76 \text{ V}$

$\therefore$  The Nernst equation for reduction potential of  $\text{Zn}^{2+}$  is

$$E = E^\circ + \frac{0.0591}{n} \log [\text{Zn}^{2+}]$$

$$E = E^\circ + \frac{0.0591}{2} \log [0.1]$$

$$E = -0.76 + (-0.02955) = -0.7925 \text{ V}$$

**Reduction potential of Zn = - 0.7925 V**

**3. Calculate the reduction potential of  $\text{Cu}^{2+}/\text{Cu} = 0.5 \text{ M}$  at  $25^\circ\text{C}$ .  $E^\circ_{\text{Cu}^{2+}/\text{Cu}} = +0.337\text{V}$**

**Solution:**

Given

Concentration of  $[\text{Cu}^{2+}] = 0.5 \text{ M}$  and  $E^\circ_{\text{Cu}^{2+}/\text{Cu}} = +0.337\text{V}$

$\therefore$  The Nernst equation for reduction potential of  $\text{Cu}^{2+}$  is

$$E = E^\circ + \frac{0.0591}{n} \log [\text{Cu}^{2+}]$$

$$E = E^\circ + \frac{0.0591}{2} \log [0.5]$$

$$E = 0.337 + (0.02955)(-0.3010) = 0.337 - 0.0089 = 0.328 \text{ V}$$

**Reduction potential of Cu = 0.328 V**

**4. Find the oxidation potential of  $\text{Zn}/\text{Zn}^{2+} = 0.2 \text{ M}$  electrode at  $25^\circ\text{C}$ . Standard oxidation potential of  $\text{Zn}/\text{Zn}^{2+}$  is  $0.763\text{V}$ . (AU 1998)**

**Solution:**

Given

Concentration of  $[\text{Zn}^{2+}] = 0.2 \text{ M}$  and  $E^\circ_{\text{Zn}/\text{Zn}^{2+}} = 0.763\text{V}$

The oxidation reaction of zinc electrode is  $\text{Zn} \longrightarrow \text{Zn}^{2+} + 2\text{e}^-$

∴ The Nernst equation for oxidation potential of  $\text{Zn}^{2+}$  is

$$E = E^{\circ} - \frac{0.0591}{n} \log [\text{Zn}^{2+}]$$

$$E = E^{\circ} - \frac{0.0591}{2} \log [0.2]$$

$$E = 0.763 - 0.02955 (-0.69897) = 0.763 + 0.02065 = 0.78365 \text{ V}$$

**Oxidation potential of Zn = 0.78365 V**

**5. What is the potential of a nickel electrode that is in contact with a solution of 0.25 M  $\text{Ni}^{2+}$  ions?  $E^{\circ}$  for  $\text{Ni} \longrightarrow \text{Ni}^{2+} + 2\text{e}^-$  is 0.24 V at 25°C.**

**Solution:**

Given

Concentration of  $[\text{Ni}^{2+}] = 0.25 \text{ M}$  and  $E^{\circ}_{\text{Ni}/\text{Ni}^{2+}} = 0.24 \text{ V}$

The oxidation reaction of nickel electrode is  $\text{Ni} \longrightarrow \text{Ni}^{2+} + 2\text{e}^-$

∴ The Nernst equation for oxidation potential of  $\text{Ni}^{2+}$  is

$$E = E^{\circ} - \frac{0.0591}{n} \log [\text{Ni}^{2+}]$$

$$E = E^{\circ} - \frac{0.0591}{2} \log [0.25]$$

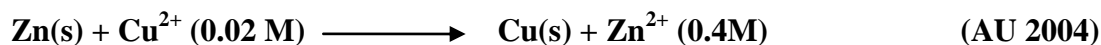
$$E = E^{\circ} + \frac{0.0591}{2} \log \frac{1}{0.25}$$

$$E = E^{\circ} + \frac{0.0591}{2} \log 4$$

$$E = 0.24 + 0.02955 (0.6021) = 0.24 + 0.017792 = 0.2578 \text{ V}$$

**Oxidation potential of Ni = 0.2578 V**

6. Find the potential of the cell in which the following reactions take place at 25°C.



**Solution:**

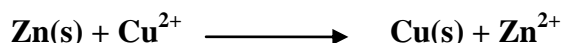
Given

$$[\text{Cu}^{2+}] = 0.02 \text{ M}, [\text{Zn}^{2+}] = 0.4\text{M}, E^{\circ}_{(\text{Zn}^{2+}/\text{Zn})} = -0.76\text{V} \text{ and } E^{\circ}_{(\text{Cu}^{2+}/\text{Cu})} = 0.34\text{V}$$

The cell is  $\text{Zn} / \text{Zn}^{2+} \parallel \text{Cu}^{2+} / \text{Cu}$

$$E^{\circ}_{\text{cell}} = E^{\circ}_{\text{R}} - E^{\circ}_{\text{L}} = E^{\circ}_{\text{Cu}} - E^{\circ}_{\text{Zn}} = 0.34 - (-0.76) = 1.10 \text{ V}$$

The cell reaction is



According to Nernst equation,  $E_{\text{cell}}$  for the given cell at 25°C

$$E = E^{\circ} - \frac{0.0591}{n} \log \frac{[\text{Product}]}{[\text{Reactant}]}$$

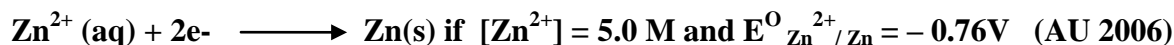
$$E_{\text{cell}} = E^{\circ}_{\text{cell}} - \frac{0.0591}{n} \log \frac{[\text{Zn}^{2+}]}{[\text{Cu}^{2+}]}$$

$$E_{\text{cell}} = 1.10 - \frac{0.0591}{2} \log \frac{[0.4]}{[0.02]}$$

$$E_{\text{cell}} = 1.10 - (0.0296) (1.30) = 1.10 - 0.03848 = 1.06 \text{ V}$$

**The potential of the cell is 1.06 V**

7. Calculate the half cell potential at 298 K for the reaction



**Solution:**

Given

$$\text{Concentration of } [\text{Zn}^{2+}] = 5.0 \text{ M and } E^{\circ}_{\text{Zn}^{2+}/\text{Zn}} = -0.76\text{V}$$

∴ The Nernst equation for reduction potential of  $\text{Zn}^{2+}$  is

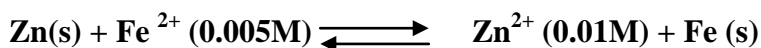
$$E = E^{\circ} + \frac{0.0591}{n} \log [\text{Zn}^{2+}]$$

$$E = E^{\circ} + \frac{0.0591}{2} \log [5]$$

$$E = -0.76 + (0.02955)(0.699) = -0.74 \text{ V}$$

**Reduction potential of Zn = - 0.74 V**

**8. Consider the cell reaction**



**Given that the standard emf of the cell is 0.323 V at 25°C. (a) Construct the cell and**

**(b) Calculate the emf of the cell.**

**(AU 2005)**

**Solution:**

The cell is :  $\text{Zn} \mid \text{Zn}^{2+} (0.01\text{M}) \parallel \text{Fe}^{2+} (0.005\text{M}) \mid \text{Fe}$

According to Nernst equation,  $E_{\text{cell}}$  for the given cell at 25°C

$$E = E^{\circ} - \frac{0.0591}{n} \log \frac{[\text{Product}]}{[\text{Reactant}]}$$

$$E_{\text{cell}} = E^{\circ}_{\text{cell}} - \frac{0.0591}{n} \log \frac{[\text{Zn}^{2+}]}{[\text{Fe}^{2+}]}$$

$$E_{\text{cell}} = 0.323 - \frac{0.0591}{2} \log \frac{[0.01]}{[0.005]}$$

$$\begin{aligned} E_{\text{cell}} &= 0.323 - (0.0296) \log 2 = 0.323 - (0.0296)(0.301) \\ &= 0.323 - 0.0089 \\ &= 0.314 \text{ V} \end{aligned}$$

**The potential of the cell is 0.314 V**

## 1.5.5 MEASUREMENT OF SINGLE ELECTRODE POTENTIAL

The absolute value of a single electrode cannot be measured experimentally because a half-cell reaction cannot take place independently. One can measure only the difference between the electrode potentials of any two half-cell reactions. If the cell potential and the electrode potential for one of the half-cell reactions are known, the electrode potential of the other electrode can be calculated.

It is not possible to measure directly the potential developed at interface of the metal and its ions in solution using voltmeter. Hence the electrode whose single electrode potential has to be determined is coupled with another electrode of known potential and the EMF of the cell is determined by the potentiometric method. Therefore, a standard hydrogen electrode is chosen and all other cell reactions are compared with this standard and a set of  $E^\circ$  values are obtained.

Normally SHE is used for coupling and in the electrochemical cell constructed; it acts either as a positive or negative electrode depending on the nature of the other electrode.

➤ When SHE acts as positive electrode, then

$$\begin{aligned} \text{E.M.F} &= E_{+ve} - E_{-ve} \\ &= E^\circ_{H_2} - E^\circ_M = 0 - E^\circ_M = - E^\circ_M \end{aligned}$$

This means when the electrode potential is positive with respect to SHE, reduction takes place at the metal electrode.

This means when the electrode potential is negative with respect to SHE, oxidation takes place at that electrode.

➤ When SHE acts as negative electrode, then

$$\begin{aligned} \text{EMF} &= E_{+ve} - E_{-ve} \\ &= E^\circ_M - E^\circ_{H_2} = E^\circ_M - 0 \quad \quad \quad E^\circ_M = + \text{ emf} \end{aligned}$$

## 1.6 TYPES OF ELECTRODES

- Reference Electrodes
- Indicator Electrodes



## 1.6.1 REFERENCE ELECTRODES (OR) STANDARD ELECTRODES

Electrodes of known potential used for the measurement of single electrode potential of a given test electrode are called **reference electrode**.

### TYPES OF REFERENCE ELECTRODES:

- Primary reference electrode – (eg) Standard Hydrogen Electrode (SHE)
- Secondary reference electrode – (eg) Calomel electrode, Quinhydrone electrode

## 1.6.2 INDICATOR ELECTRODE

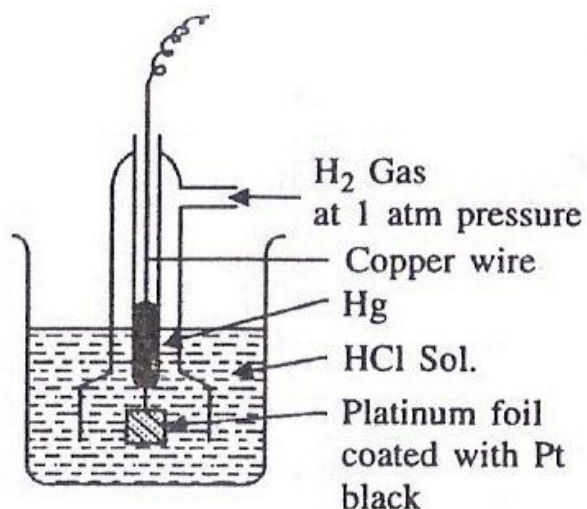
The electrode whose potential changes with change in concentration is known as indicator electrode.

Mostly inert metals like Pt, Ag are used as indicator electrodes for potentiometric titrations involving redox systems.

## 1.6.3 STANDAR HYDROGEN ELECTRODE (SHE)

(PRIMARY REFERENCE ELECTRODE)

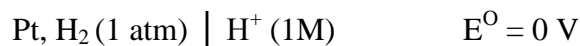
*SHE is called as the Primary Reference Electrode* because the EMF developed by it is arbitrarily fixed as zero at 1 atmospheric pressure and the value is treated as constant at all temperature, otherwise determination of potentials of all other electrodes is impossible. It is the electrode with which the potentials of other electrodes are compared.



**Fig 1.6 Standard Hydrogen Electrode**

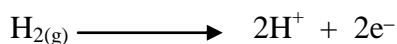
## CONSTRUCTION:

It consists of a rectangular platinum foil connected to a Pt wire and sealed in a glass tube. A glass envelope surrounds the tube carrying the Pt foil. The jacket is closed at the top and open at the bottom. A side arm is attached to the outer jacket through which hydrogen gas is passed into the cell. This electrode when dipped in a 1M HCl solution and H<sub>2</sub> gas at 1 atmospheric pressure is passed forms a SHE. **The electrode is represented as :**



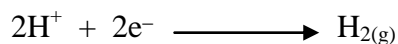
The electrode potential of SHE is **zero**.

In a cell, when this electrode acts as **anode**, the electrode reaction is



Thus, a part of H<sub>2</sub> gas changes into ions and goes into the solution.

When this electrode acts as **cathode**, the electrode is



Thus, some of the ions from the solution change into H<sub>2</sub> gas.

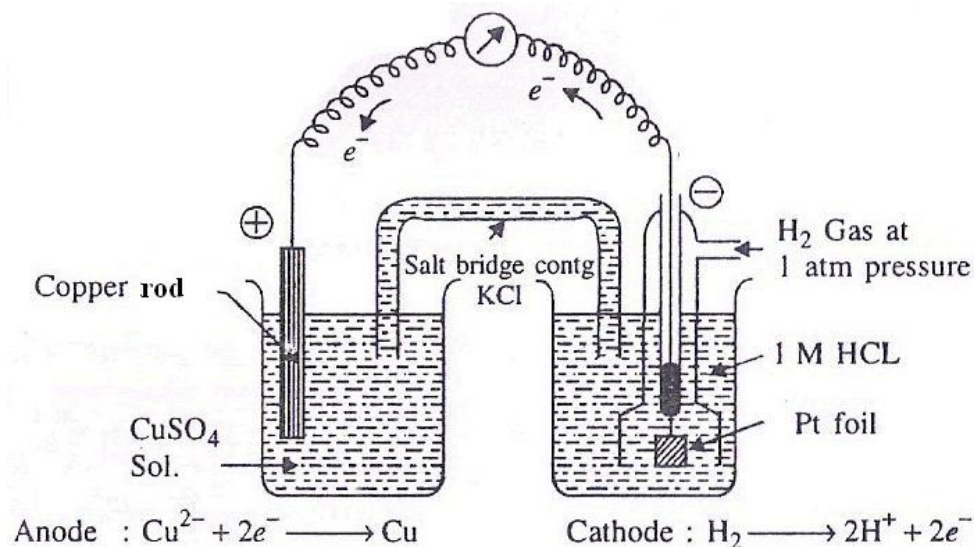
## LIMITATIONS OF SHE:

- It is very difficult to set up the SHE as it is difficult to maintain unit activity of H<sup>+</sup> ion in solution and 1 atmospheric pressure of H<sub>2</sub> gas uniformly.
- Oxidizing species and even traces of impurities in gas can poison the platinum electrode.
- SHE requires large volume of electrolyte solution.
- The potential of the electrode varies when there is change in atmospheric pressure.

## 1.6.4 MEASUREMENT OF ELECTRODE POTENTIAL OF Cu<sup>2+</sup>/ Cu

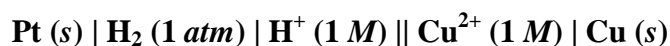
### ELECTRODE USING SHE

To determine the cell potential of Cu<sup>2+</sup>/ Cu electrode a cell made of a copper electrode immersed in 1 M CuSO<sub>4</sub> solution and standard hydrogen electrode are connected to a voltmeter. The EMF of the cell is 0.34 V. Oxidation occurs at the S.H.E. electrode, which acts as the anode whereas reduction occurs at the copper electrode, which acts as the cathode.

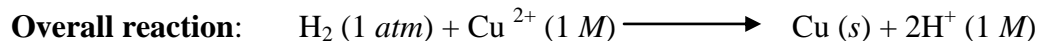
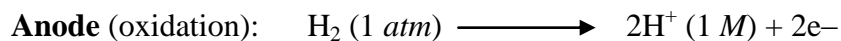


**Fig. 1.7 Measurement of standard electrode potential Cu using SHE**

**Cell representation:**



**Cell reaction:**



The EMF of the cell is:

$$E^{\circ}_{\text{cell}} = E^{\circ}_{\text{R}} - E^{\circ}_{\text{L}}$$

$$E^{\circ}_{\text{cell}} = E^{\circ}(\text{Cu}^{2+} \mid \text{Cu}) - E^{\circ}(\text{H}_2 \mid \text{H}^+)$$

$$0.34 = E^{\circ}(\text{Cu}^{2+} \mid \text{Cu}) - 0$$

$$\text{or } E^{\circ}(\text{Cu}^{2+} \mid \text{Cu}) = 0.34\text{V.}$$

Thus, the standard electrode potential of Cu is + 0.34 V. In this case, the electron accepting tendency of the electrode is more than that of a S.H.E. and hence its standard reduction potential gets a positive sign.

## 1.6.5 MEASUREMENT OF ELECTRODE POTENTIAL OF $\text{Zn}^{2+}/\text{Zn}$ ELECTRODE USING SHE

To determine the cell potential of  $\text{Zn}/\text{Zn}^{2+}$  electrode a cell made of a Zn electrode immersed in 1M  $\text{ZnSO}_4$  is coupled with a S.H.E. The E.M.F. of the above cell is 0.76V. The direction of flow indicates that oxidation takes place so a standard reduction potential of  $-0.76\text{V}$  is given to it.

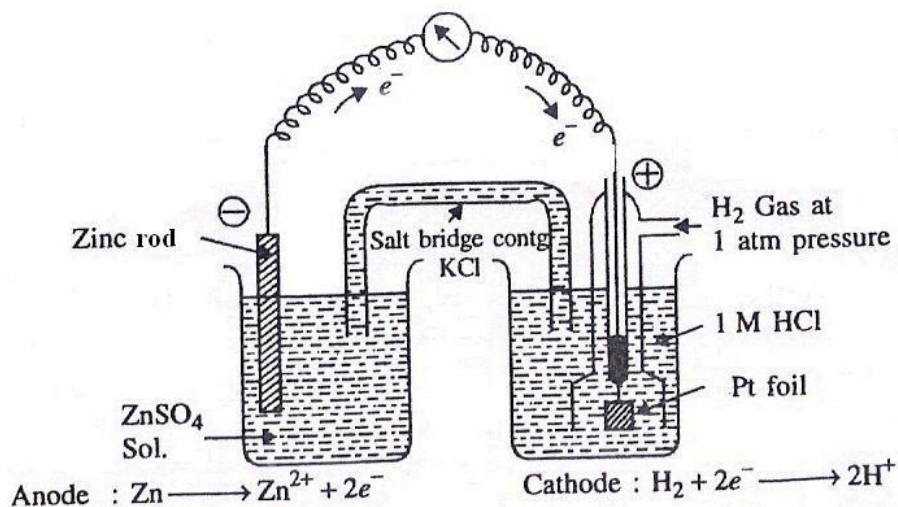
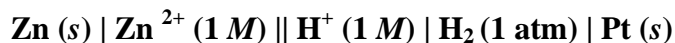
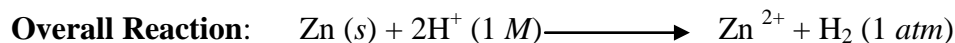
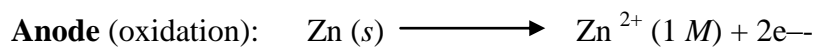


Fig. 1.8 Measurement of standard electrode potential Zn using SHE

**Cell representation:**



**Cell reaction:**



EMF of the cell:  $E^{\circ}_{\text{cell}} = E^{\circ}_{\text{R}} - E^{\circ}_{\text{L}}$

$$E^{\circ}_{\text{cell}} = E^{\circ} (\text{H}^{+}/\text{H}_2) - E^{\circ} (\text{Zn} / \text{Zn}^{2+})$$

$$+0.76\text{V} = 0 - E^{\circ} (\text{Zn} / \text{Zn}^{2+})$$

$$E^{\circ} (\text{Zn} / \text{Zn}^{2+}) = -0.76\text{V}$$

Thus, the standard electrode potential of Zn is  $-0.76$  V. In this case, the electron accepting tendency of the metal electrode is lesser than that of S.H.E. and hence its standard reduction potential gets a negative sign.

It must be remembered that according to latest convention standard potentials are taken as reduction potentials. The electrode at which reduction occurs with respect to S.H.E. has **positive** reduction potential. The electrode at which oxidation occurs with respect to S.H.E. has **negative** reduction potential.

### 1.6.6 SATURATED CALOMEL ELECTRODE

#### (SECONDARY REFERENCE ELECTRODE)

To overcome the difficulties of setting up of hydrogen electrode the secondary electrode was developed. The electrode potential of calomel electrode is determined by connecting it to SHE whose potential is arbitrarily taken as zero at all temperature. *Since calomel electrode is used to measure the electrode potential of all other electrodes instead of SHE it is called as secondary reference electrode.*

#### CONSTRUCTION:

Pure mercury is placed at the bottom of a glass tube having a side tube on each side. Mercury is covered by a paste of mercurous chloride (calomel). A saturated solution of KCl is introduced above the paste through the side tube shown on the left. The solution also fills the side tube ending in a jet on the right which is used for making electrical contact with a salt bridge. A Pt wire is sealed into a glass tube serves to make electrical contact of the electrode with the circuit.

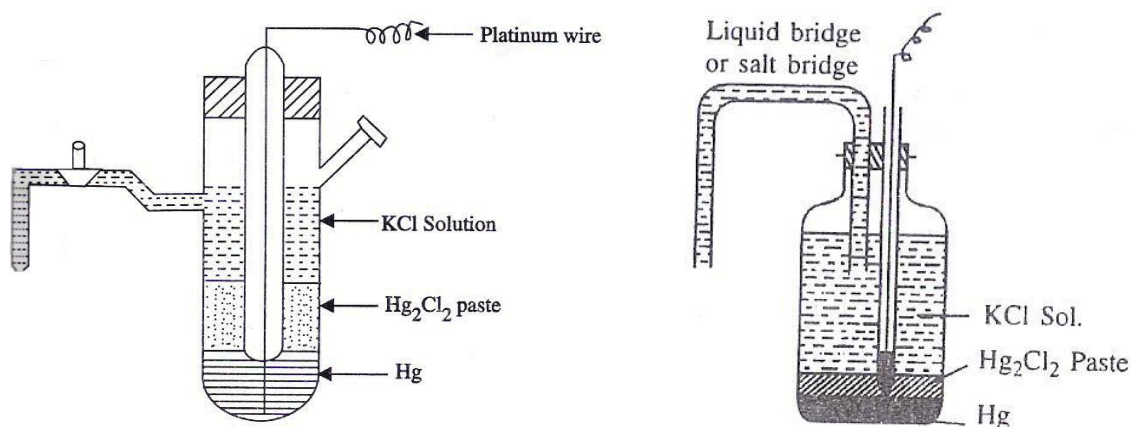
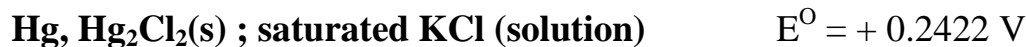
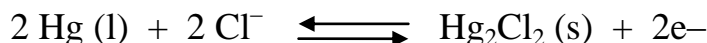


Fig. 1.9 Calomel Electrode

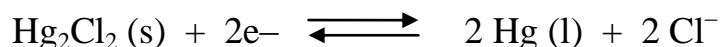
The standard calomel electrode is represented as:



If the electrode acts as **anode**, it undergoes oxidation liberating electrons and send  $Hg_2^{2+}$  ions into the solution. The  $Hg_2^{2+}$  ions would combine with  $Cl^-$  ions (furnished by KCl) forming sparingly soluble  $Hg_2Cl_2$ . The result is a fall in the concentration of  $Cl^-$  ions in the solution.



If the electrode acts as cathode, the electrode reaction involves reduction; the  $Hg_2^{2+}$  ions furnished by sparingly soluble mercurous chloride would be discharged at the electrode. Hence more and more calomel would pass into solution. The result is an increase in the concentration of  $Cl^-$  ions.



The electrode is reversible w.r.t. chloride ions.

### Characteristics of calomel electrode:

- The electrode potential of calomel electrode depends on the activity of chloride ions and it increases as the activity of chloride ion decreases.
- The single electrode potential of calomel electrode at various concentration of KCl on hydrogen scale at 298 K is:

| [KCl] N   | Reduction Potential (E V) |
|-----------|---------------------------|
| 0.1 N     | + 0.3338 V                |
| 1 N       | + 0.2810 V                |
| Saturated | + 0.2422 V                |

$$\begin{aligned} \text{EMF}_{\text{cell}} &= E^{\circ}_{\text{R}} - E^{\circ}_{\text{L}} \\ &= E^{\circ}_{\text{calomel}} - E^{\circ}_{\text{SHE}} \end{aligned}$$

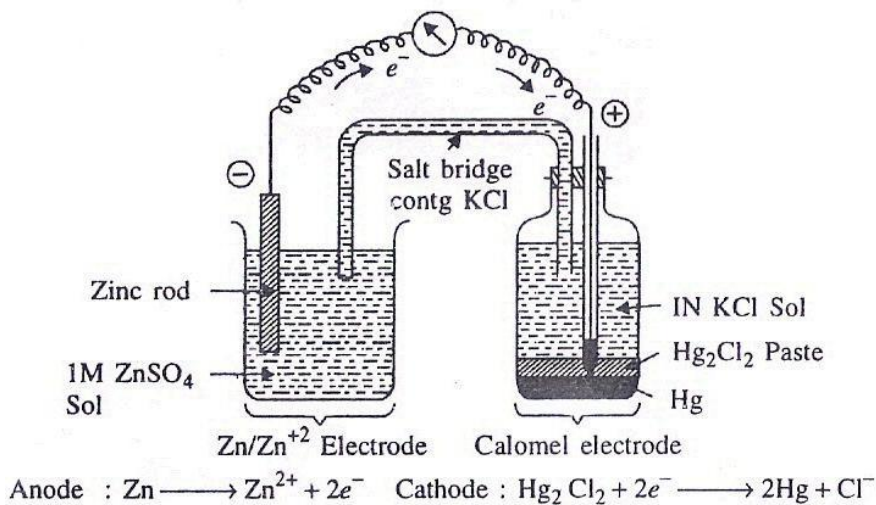
$$0.2442 \text{ V} = E^{\circ}_{\text{calomel}} - 0 \text{ V}$$

$$E^{\circ}_{\text{calomel}} = + 0.2442 \text{ V}$$

- The potential of calomel electrode is temperature dependent.
- The positive value indicates that, when combined with SHE, reduction takes place at this electrode.

### 1.6.7 MEASUREMENT OF ELECTRODE POTENTIAL OF $Zn^{2+}/Zn$ ELECTRODE USING SATURATED CALOMEL ELECTRODE

To determine the cell potential of  $Zn/Zn^{2+}$  electrode, a cell made of a Zn electrode immersed in 1M  $ZnSO_4$  is coupled with a saturated calomel electrode. The E.M.F. of the above cell is 1.0022 V at 25°C. The direction of flow of current indicates that oxidation takes place at the Zn electrode. Thus Zn electrode is anode and the calomel electrode is cathode.



**Fig 1.10 Measurement of electrode potential Zn using saturated calomel electrode**

The cell may be represented as:



$$EMF_{cell} = E^{\circ}_R - E^{\circ}_L = E^{\circ}(\text{calomel}) - E^{\circ}(Zn / Zn^{2+})$$

$$1.0022 \text{ V} = +0.2422 \text{ V} - E^{\circ}(Zn / Zn^{2+})$$

$$E^{\circ}(Zn / Zn^{2+}) = +0.2422 - 1.0022 = -0.76 \text{ V}$$

$$E^{\circ}(Zn / Zn^{2+}) = -0.76 \text{ V}$$

Thus, the standard electrode potential of Zn is  $-0.76 \text{ V}$ . The reduction reaction is not feasible w.r.t. SCE and hence the electrode acts as anode while SCE act as cathode. The negative sign of the measured EMF indicates that the reaction proceed in opposite direction w.r.t. SCE.

### 1.6.8 ION-SELECTIVE ELECTRODE (ISE)

This type of electrode will respond **only to a specific or particular ion**. They develop a potential with respect to that ion only and all other ions present in a mixture will have practically

no contribution (i.e. ignoring the other ions in a mixture totally). The potential developed by an ion selective electrode depends only on the concentration of specific or particular ions.

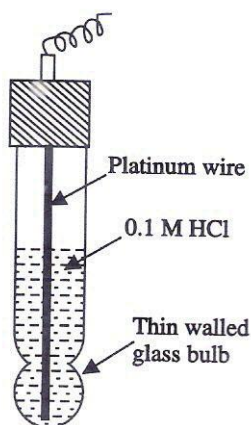
**Example:** Glass electrode

### 1.6.8 GLASS ELECTRODE

(INTERNAL REFERENCE ELECTRODE or INDICATOR ELECTRODE)

Glass electrode is a type of ISE used in pH measurements. It will respond only to  $H^+$  ion in a solution. The potential of this electrode depends on the pH of the solution.

#### CONSTRUCTION:



**Fig. 1.11 Glass electrode**

A glass electrode consists of a long glass tube with thin walled glass bulb at the bottom. The bulb is made up of a special glass having low melting point and high electrical conductivity. The electrode is filled with 0.1M HCl which furnishes a constant  $H^+$  ion concentration. The glass tube is sealed by Ag wire coated with AgCl or Pt wire to make electrical contact.

The glass electrode is represented as:



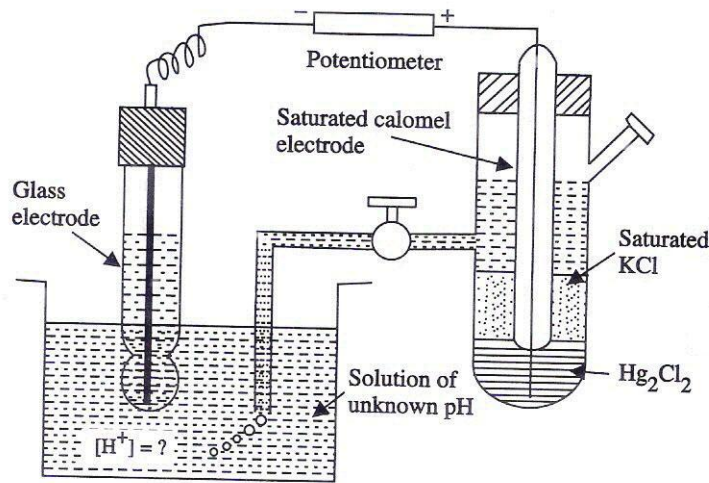
Glass electrode is constructed on the principle that when two solutions of different pH values are separated by a thin glass membrane, there develops a potential difference between the two surfaces of the membrane. The potential difference developed is proportional to the difference in pH value. The glass membrane (thin walled glass bulb) functions as an ion exchange resin and an equilibrium is set up between the  $Na^+$  ions of the glass and  $H^+$  ions in solution. The potential difference varies with the  $H^+$  ion concentration and is given by the expression.



$$E_G = E_G^{\circ} - 0.0591 \text{ V pH (at } 25^{\circ}\text{C)}$$

### 1.6.9 DETERMINATION OF pH OF A SOLUTION USING GLASS ELECTRODE

To determine the pH of a solution, the glass electrode is placed in the solution under test and coupled with saturated calomel electrode. The EMF of the cell is measured potentiometrically.



**Fig 1.12 Measurement of pH using glass electrode**

The complete cell is represented as:



From the EMF, the pH of the test solution can be calculated as follows:

$$E_{\text{cell}} = E_R - E_L = E_{\text{calomel}} - E_{\text{glass}}$$

$$E_{\text{cell}} = 0.2422 \text{ V} - (E_G^{\circ} - 0.0591 \text{ pH})$$

$$= 0.2422 \text{ V} - E_G^{\circ} + 0.0591 \text{ pH}$$

$$E_{\text{cell}} - 0.2422 \text{ V} + E_G^{\circ} = 0.0591 \text{ pH}$$

$$\text{pH} = \frac{E_{\text{cell}} - 0.2422 \text{ V} + E_G^{\circ}}{0.0591}$$

**Determination of  $E_G^{\circ}$  value:** A solution of known pH is taken in a beaker. The glass electrode is introduced into it. Then it is coupled with calomel electrode. The EMF is determined potentiometrically. From the EMF of the cell,  $E_G^{\circ}$  can be calculated because the pH value is already known. The value of  $E_G^{\circ}$  is first obtained by working with solutions of known pH values.

### 1.6.6 ADVANTAGES OF GLASS ELECTRODE

- It can be easily constructed and is simple to operate.
- The results are more accurate.
- A small quantity of solution is sufficient for the determination of pH.
- It is not easily poisoned.
- Its activity is not affected by strong oxidizing and reducing agents.
- Equilibrium is rapidly achieved.

### 1.6.7 DISADVANTAGES OF GLASS ELECTRODE

- The glass membrane of the electrode used in the bulb is very thin and its resistance is high. Therefore electronic potentiometers are needed for the measurements.
- It cannot be used in strongly alkaline solution ( $\text{pH} > 10$ ), since the cations of the solution affect the glass and make the electrode useless.

### 1.6.8 APPLICATIONS OF ISEs

- ISEs are used in determining the concentrations of cations like  $\text{H}^+$ ,  $\text{Na}^+$ ,  $\text{K}^+$ ,  $\text{Ag}^+$ ,  $\text{Li}^+$ .
- ISEs are used for the determination of hardness ( $\text{Ca}^{2+}$  and  $\text{Mg}^{2+}$  ions).
- Concentration of anions like  $\text{NO}_3^-$ ,  $\text{CN}^-$ ,  $\text{S}^{2-}$ , halides ( $\text{X}^-$ ) can be determined.
- ISEs are used in the determination of concentration of a gas by using gas-sensing electrodes.

## 1.7 ELECTROCHEMICAL SERIES (OR) EMF SERIES

Different electrodes have different standard electrode potentials. The standard electrode potentials ( $E^\circ$ ) for some electrodes are negative, while for some others  $E^\circ$  values are positive. The  $E^\circ$  values of many electrodes have been measured and their standard reduction potentials are arranged in a sequential order.

The arrangement of elements in the order of increasing reduction potential values w.r.t. SHE is called **electrochemical series or activity series**.

Standard reduction electrode potentials of a few elements at 298 K are shown:

| Electrode                             | Electrode reactions   | E°volts |
|---------------------------------------|---|---------|
| Li <sup>+</sup>   Li                  | Li <sup>+</sup> (aq) + e <sup>-</sup> → Li(s)                   | -3.05   |
| K <sup>+</sup>   K                    | K <sup>+</sup> (aq) + e <sup>-</sup> → K(s)                     | -2.93   |
| Mg <sup>2+</sup>   Mg                 | Mg <sup>2+</sup> (aq) + 2e <sup>-</sup> → Mg(s)                 | -2.37   |
| Al <sup>3+</sup>   Al                 | Al <sup>3+</sup> (aq) + 3e <sup>-</sup> → Al(s)                 | -1.66   |
| Zn <sup>2+</sup>   Zn                 | Zn <sup>2+</sup> (aq) + 2e <sup>-</sup> → Zn(s)                 | -0.76   |
| Fe <sup>2+</sup>   Fe                 | Fe <sup>2+</sup> (aq) + 2e <sup>-</sup> → Fe(s)                 | -0.44   |
| Cd <sup>2+</sup>   Cd                 | Cd <sup>2+</sup> (aq) + 2e <sup>-</sup> → Cd(s)                 | -0.40   |
| Ni <sup>2+</sup>   Ni                 | Ni <sup>2+</sup> (aq) + 2e <sup>-</sup> → Ni(s)                 | -0.25   |
| Pb <sup>2+</sup>   Pb                 | Pb <sup>2+</sup> (aq) + 2e <sup>-</sup> → Pb(s)                 | -0.13   |
| Pt, H <sup>+</sup>   H                | 2H <sup>+</sup> (aq) + 2e <sup>-</sup> → H <sub>2</sub> (g)     | 0.00    |
| Cu <sup>2+</sup>   Cu                 | Cu <sup>2+</sup> (aq) + 2e <sup>-</sup> → Cu(s)                 | +0.34   |
| I <sub>2</sub>   I <sup>-</sup>       | I <sub>2</sub> (s) + 2e <sup>-</sup> → 2I <sup>-</sup> (aq)     | +0.54   |
| Fe <sup>3+</sup>   Fe <sup>2+</sup>   | Fe <sup>3+</sup> (aq) + 2e <sup>-</sup> → Fe <sup>2+</sup> (aq) | +0.77   |
| Hg <sub>2</sub> <sup>2+</sup>   Hg    | Hg <sub>2</sub> <sup>2+</sup> (aq) + 2e <sup>-</sup> → Hg(l)    | +0.79   |
| Ag <sup>+</sup>   Ag                  | Ag <sup>+</sup> (aq) + e <sup>-</sup> → Ag(s)                   | +0.80   |
| Br <sub>2</sub>   Br <sup>-</sup>     | Br <sub>2</sub> (aq) + 2e <sup>-</sup> → 2Br <sup>-</sup> (aq)  | +1.08   |
| Pt, Cl <sub>2</sub>   Cl <sup>-</sup> | Cl <sub>2</sub> (aq) + 2e <sup>-</sup> → 2Cl <sup>-</sup> (s)   | +1.36   |
| Au <sup>3+</sup>   Au                 | Au <sup>3+</sup> (aq) + 3e <sup>-</sup> → Au(s)                 | +1.50   |

a\* = increasing tendency for oxidation to lose electrons as strong reducing agent

b\* = increasing tendency for reduction to gain electrons as strong oxidizing agent

## 1.7.1 APPLICATION OF EMF SERIES

### ➤ Oxidizing and Reducing Strengths:

The electrochemical series helps to pick out substances that are good oxidizing agents and reducing agents.

**For example**, a very high negative reduction potential of lithium electrode indicates that it is very difficult to reduce  $\text{Li}^+$  ions to Li atoms. Therefore,  $\text{Li}^+$  cannot accept electrons easily and so loses electrons to behave as a reducing agent.

As the reduction potential increases (negative value decreases), the tendency of the electrode to behave as reducing agent decreases. Thus, all the substances appearing on the top of the series behave as good reducing agents.

For **example** Li and K are good reducing agents while  $\text{F}^-$  and Au are the poorest reducing agents. Similarly, substances at the bottom of the table have high reduction potential and they can be easily reduced. Therefore, they act as strong oxidizing agents.

Thus, **all the substances appearing at the bottom of the table are good oxidizing agents and all the substances appearing at the top of the table are good reducing agents.**

### ➤ Relative ease of oxidation or reduction:

The  $E^\circ$  value of an electrode gives the relative tendency for the reduction reaction to occur at the electrode. Therefore, the electrodes with positive electrode potentials show greater tendency towards reduction. On the other hand, the electrodes with negative electrode potentials show lesser tendency towards reduction (i.e) they are more easily oxidised.

**Example:** Fluorine has higher positive value of standard reduction potential (+2.87V) and has higher tendency towards reduction. Lithium has highest negative value (– 3.01V) and shows higher tendency towards oxidation.

### ➤ Calculation of the Standard EMF of the Cell:

The standard EMF of the cell can be calculated from the standard reduction potential values, using the following relation

$$E^\circ_{\text{cell}} = E^\circ_{\text{R}} - E^\circ_{\text{L}}$$

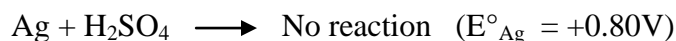
If the EMF of the cell is positive, the reaction is feasible in the given direction and the cell is correctly represented, i.e., oxidation occurs at left electrode (anode) and reduction occurs at the right electrode (cathode).

If it is negative, the cell reaction is not feasible in the given direction and the cell is wrongly represented. Thus, to get positive value for the EMF the electrodes must be reversed.

### ➤ **Predicting the Liberation of Hydrogen Gas from Acids by Metals:**

All metals having negative electrode potentials (negative  $E^\circ$  values) show greater tendency of losing electrons as compared to hydrogen. So, when such a metal is placed in an acid solution, the metal gets oxidized, and  $H^+$  (hydrogen) ions get reduced to form hydrogen gas. Thus, the metals having negative  $E^\circ$  values liberate hydrogen from acids.

For **example**, metals such as Mg ( $E_{(Mg^{2+}/Mg)} = -2.37\text{ V}$ ), Zn ( $E_{(Zn^{2+}/Zn)} = -0.76\text{ V}$ ), Iron ( $E_{(Fe^{2+}/Fe)} = -0.44\text{ V}$ ) etc., can displace hydrogen from acids such as HCl and  $H_2SO_4$ . But metals such as Copper, ( $E_{(Cu^{2+}/Cu)} = +0.34\text{ V}$ ), silver ( $E_{(Ag^+/Ag)} = +0.80\text{ V}$ ) and gold ( $E_{(Au^{3+}/Au)} = +1.42\text{ V}$ ) cannot displace hydrogen from acids because of their positive reduction potential value.



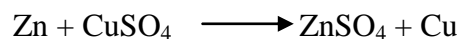
### ➤ **Displacement of one element by the other:**

A metal having smaller reduction potential can displace metals having larger reduction potentials from the solution of their salt under suitable conditions.

In general a metal occupying higher position in the series can displace the metals lying below it from the solutions of their salts and so are more reactive in displacing the other metals.

Thus, Li is the most electropositive element in solutions and fluorine is the most electronegative element.

For **example**, we may know whether Cu will displace Zn from the solution or vice-versa. The standard reduction potential of Cu & Zn are  $E^\circ_{Cu^{2+}/Cu} = +0.34\text{ V}$  and  $E^\circ_{Zn^{2+}/Zn} = -0.76\text{ V}$ . Hence Zn rod dipped in  $CuSO_4$  solution will displace copper.



- Thus a metal which lie higher in the series will displace, any other metal, which lie below it in the series from its salt solution.
- When a metal having lower  $E^\circ$  value is placed in a solution, containing ions of another metal having higher  $E^\circ$  value, then the metal having lower  $E^\circ$  value gets dissolved and the ions of the metal having higher  $E^\circ$  value get precipitated.

➤ **Determination of equilibrium constant (K) for a reaction:**

We know that,

$$-\Delta G^\circ = +RT \ln K = 2.303 RT \log K$$

$$\log K = \frac{-\Delta G^\circ}{2.303 RT} = \frac{nF E^\circ}{2.303 RT} = \frac{n E^\circ}{0.0591}$$

From the value of  $E^\circ$ , the equilibrium constant for the reaction can be obtained.

➤ **Predicting the spontaneity of redox reaction:**

The standard electrode potential is related to free energy change as

$$\Delta G^\circ = -n F E^\circ$$

For a reaction to be spontaneous, the general criterion is that  $\Delta G$  should be negative i.e. the reaction proceeds with decrease in free energy.

Hence if  $E^\circ$  of the cell is positive, the cell reaction is spontaneous.

(i.e)  $\Delta G =$  negative when  $E^\circ$  is positive

If  $E^\circ$  of the cell is negative, the cell reaction is not feasible.

(i.e)  $\Delta G =$  positive when  $E^\circ$  is negative

## 1.8 ELECTROMOTIVE FORCE (EMF) OF A CELL

Electricity cannot flow from one point to another unless there is a potential difference between the two points. Hence, the flow of electricity from one electrode to another in a galvanic cell indicates that the two electrodes have different potentials. *The difference of potential which causes flow of electrons from one electrode (which is at a higher potential) to another electrode (which is at a lower potential) is called **Electromotive force** (EMF).*

Oxidizing agent pulls the electron. Reducing agent pushes the electron. The push or pull (“driving force”) is called the EMF. It is also called the cell potential and is designated as  $E_{\text{cell}}$ .

Cell potential is measured in volts (V). It is measured with a voltmeter. The cell potential depends on the relative ease with which the oxidizing agent is reduced at the cathode and the reducing agent is oxidized at the anode.

For 1M solutions at 25°C (standard conditions), the standard EMF (standard cell potential) is called  $E^{\circ}_{\text{cell}}$ .

Standard reduction potentials,  $E^{\circ}_{\text{red}}$  are measured relative to the standard hydrogen electrode (SHE).

### STANDARD CELL POTENTIAL

The cell potential at standard conditions can be calculated by using the following relationship:

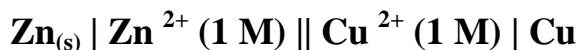
$E^{\circ}_{\text{cell}} = (\text{Standard reduction potential of RHS electrode}) - (\text{Standard reduction potential of LHS electrode})$

$$E^{\circ}_{\text{cell}} = E^{\circ}_{\text{R}} - E^{\circ}_{\text{L}}$$

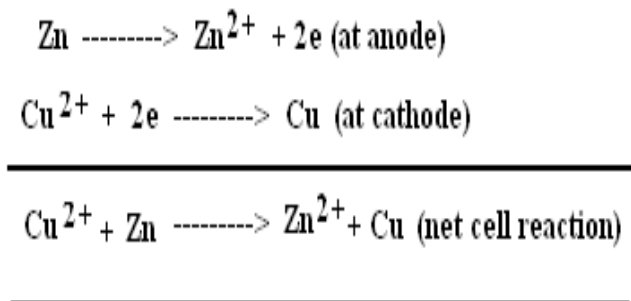
$$E^{\circ}_{\text{cell}} = E^{\circ}_{(\text{cathode})} - E^{\circ}_{(\text{anode})}$$

**Example:** Nernst equation for EMF of a cell

The Daniel cell can be represented as



The cell reaction is



The EMF of the cell is given as

$$E_{\text{cell}} = E_{\text{Cu}} - E_{\text{Zn}} \quad \dots\dots\dots (1)$$

We know that, the Nernst equation for reduction potential of Cu is

$$E_{\text{Cu}} = E_{\text{Cu}}^{\circ} + \frac{0.0591}{n} \log [\text{Cu}^{2+}] \quad \dots\dots\dots(2)$$

Similarly, the Nernst equation for reduction potential of Zn is

$$E_{\text{Zn}} = E_{\text{Zn}}^{\circ} + \frac{0.0591}{n} \log [\text{Zn}^{2+}] \quad \dots\dots\dots(3)$$

Substituting equation (2) & (3) in (1), we get

$$E_{\text{cell}} = (E_{\text{Cu}^{2+}/\text{Cu}}^{\circ} - E_{\text{Zn}^{2+}/\text{Zn}}^{\circ}) + \frac{0.0591}{2} \log \frac{[\text{Cu}^{2+}]}{[\text{Zn}^{2+}]}$$

This is the Nernst equation for EMF of a Daniel cell.

**CALCULATION OF CELL POTENTIAL FOR DANIEL CELL**

For the oxidation in this cell,  $E_{\text{red}} = -0.76 \text{ V}$

For the reduction,  $E_{\text{red}} = +0.34 \text{ V}$

$$E_{\text{cell}}^{\circ} = E_{\text{(cathode)}}^{\circ} - E_{\text{(anode)}}^{\circ} = +0.34 \text{ V} - (-0.76 \text{ V}) = +1.10 \text{ V}$$

**1.8.1 MEASUREMENT OF EMF OF A CELL**

The EMF of a cell can be measured by connecting the two electrodes to the two terminals of a voltmeter. The potential difference can be read directly from the instrument. But this method, however, suffer from the following defects:

- 1) A part of cell current is drawn from the cell during the process of measurement itself. The chemical reaction occurs to some extent. This alters the concentration of the electrolytes, e.g.  $\text{ZnSO}_4$  or  $\text{CuSO}_4$  in the Daniel cell, around the electrodes. Hence, the actual EMF of the cell is altered.
- 2) Secondly, with flow of current, a part of the EMF is used up in overcoming the internal resistance of the cell.

Hence, the potential difference as read from the voltmeter will not be *correct EMF* of the cell.

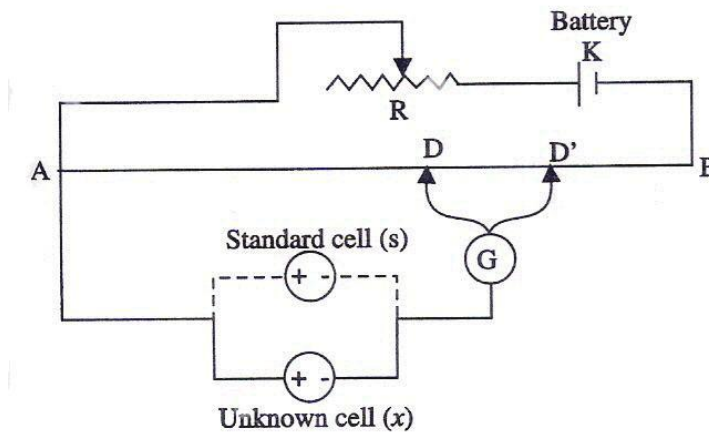
To get accurate EMF of a cell, potentiometers are used which involves little or no flow of electricity. Such a method is based on **Poggendorff's Compensation principle**.



## DETERMINATION OF EMF OF A CELL BY POGGENFORFF'S COMPENSATION METHOD: (POTENTIOMETER METHOD)

**PRINCIPLE:** In this method, the EMF of the unknown cell is opposed or balanced by an external EMF (EMF of standard cell) so that no current flows in the circuit. At this stage, the applied EMF is equal to the magnitude of EMF of the unknown cell.

**DESCRIPTION:** The potentiometer consists of a primary circuit and a secondary circuit.



**Fig 1.13 Potentiometer for the measurement of EMF**

The **primary circuit** consists of a storage battery (K) (the EMF of must be larger than the EMF of the cell to be measured), a potentiometer wire, AB of uniform cross-sectional area having high resistance and a rheostat, R. The two ends of the potentiometer wire are connected to storage battery through a rheostat. The rheostat is adjusted in the circuit, in such a way, a constant current, 'i' is sent through the potentiometer wire.

The **secondary circuit** consists of a standard cell (S), an unknown cell (X), a galvanometer (G) and a sliding contact (D). The standard cell and the unknown cell are connected in the circuit through a DPDT key (Double Pole Double Throw key).

### DETERMINATION:

The unknown cell (X), the EMF of which is to be determined is included in the circuit by connecting its positive pole to A and the negative pole is connected to the sliding contact (D) through a galvanometer (G) by DPDT key. The sliding contact is moved along the wire AB and

the rheostat is adjusted till zero deflection is obtained in the galvanometer (i.e. no current flow through G). The position of 'D' is noted.

The potential difference between the point A and D can be determined using Ohm's law. Since a uniform cross-sectional potentiometer wire is used in the circuit, resistance of AD is directly proportional to the length of the wire. Therefore at null deflection, the potential difference between A & D just balances the EMF;  $E_X$  of the unknown cell, X. Distance AD is measured and is directly proportional to the EMF of the unknown cell.

EMF of the unknown cell = Potential difference between the point A and D

$$E_S = 'i' \times \text{Resistance of AD}$$

$$E_S = 'i' \times \text{length AD} \quad \dots\dots\dots(1)$$

The unknown cell (X) is now replaced by a standard cell (S), the EMF ( $E_S$ ) of which is known. The sliding contact is moved upto point D' till there is null deflection in the galvanometer. At this stage, the potential difference of standard cell is exactly balanced by the external source (K). Distance AD' is measured and is directly proportional to the EMF of the standard cell.

EMF of the standard cell,  $E_S = 'i' \times \text{length AD}' \quad \dots\dots\dots(2)$

From equation (1) & (2), the EMF of the unknown cell can be calculated as follows:

$$\frac{\text{EMF of the unknown cell } (E_X)}{\text{EMF of the standard cell } (E_S)} = \frac{\text{length AD}}{\text{length AD}'}$$

$$\frac{E_X}{E_S} = \frac{AD}{AD'}$$

$$\text{EMF of the unknown cell, } E_X = \frac{AD}{AD'} \times E_S$$

### 1.8.2 FACTORS AFFECTING EMF OF A CELL

- Nature of the electrolytes and electrodes.
- Concentration and composition of the electrolytes.
- pH and temperature of the solution.

### 1.8.3 APPLICATIONS OF EMF MEASUREMENTS

- The valency of an ion can be determined.
- Solubility of a sparingly soluble salt can be determined.

- Hydrolysis constant can be determined.
- Determination of standard free energy change and equilibrium constant.
- Determination of pH using a SHE
- Potentiometric titrations can be carried out to estimate strength of solutions

## 1.9 REVERSIBLE AND IRREVERSIBLE CELLS

Electrochemical cells may be **reversible** and **irreversible cells**.

The reactions in a reversible cell are always in a state of equilibrium and only infinitesimally small currents are drawn from it.

### 1.9.1 REVERSIBLE CELLS

The cells which obey the following three conditions of thermodynamic reversibility are called reversible cells.

#### ➤ Condition 1:

When the cell is connected to an external source of EMF exactly equal to that of the cell EMF, no current flows through the cell and no chemical reaction takes place. Such cells are called as reversible cells.

#### ➤ Condition 2:

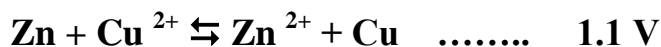
If the external EMF is infinitely greater than that of the cell EMF, an extremely small amount of current flows through the cell in the opposite direction and the chemical changes which occur in the cell due to the current produced should be exactly reversed.

#### ➤ Condition 3:

If the external EMF is infinitely smaller than that of the cell EMF, then the current should flow from the cell to the external source.

#### **Example: Daniel cell**

Its cell potential is 1.1 V. Thus in Daniel cell (a galvanic cell), zinc undergoes dissolution and copper undergoes deposition to produce an EMF of 1.1V, as per the following reaction sequence:





**Fig 1.14 Daniel Cell**

If the external EMF becomes exactly equal to that of cell EMF i.e. 1.1V, no current flows and the cell reaction stops.



If the external EMF is increased infinitely beyond 1.1V, current flows in the opposite direction and the cell reaction is reversed.



When the two electrodes are connected to an external source of EMF infinitely smaller than 1.1V, the current flows from the zinc electrode to the copper electrode.



This process continues as the external opposing EMF is infinitely smaller than that of the cell.

## 1.9.2 IRREVERSIBLE CELLS

The cells which do not obey the conditions of thermodynamic reversibility are called **irreversible cells**.

**Example:** A cell consisting of zinc and copper electrodes dipped into a solution of sulphuric acid is irreversible.

The cell when connected to an external source of EMF slightly smaller than that of the cell, zinc dissolves in sulphuric acid forming zinc sulphate with the evolution of hydrogen. The cell reaction is:



If the EMF of the external source is slightly greater than that of the cell, copper goes into solution, hydrogen is liberated at the other electrode and the reaction is



It is clear from the above reactions that the cell is not reversible; in each case different sets of products are formed.

Similarly, the cell:  $\text{Zn} | \text{H}_2\text{SO}_4(\text{aq}) | \text{Ag}$

is also irreversible because when the external EMF is greater than the EMF of the cell, the cell reaction,



is not reversed but the cell reaction becomes



Irreversible is a cell where the cell reaction cannot be reversed even on applying infinitesimally small but excess applied EMF i.e. the products produced during the cell reaction are not available for recombination on reversal of voltage.

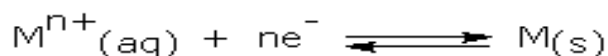
## 1.10 POTENTIOMETRIC TITRATIONS

### PRINCIPLE:

One of the most important practical applications of EMF measurement is to determine the end point of various types of titrations. Potentiometric titrations are special type of volumetric analysis in which the end point of the titration is obtained by potential measurements. These titrations are also known as electrometric titrations.

It is known that the potential of an electrode when dipped in the solution of an electrolyte depends upon the concentration of certain ions with which the electrode is in contact. Hence the determination of the potential can be used as an indicator in volumetric analysis.

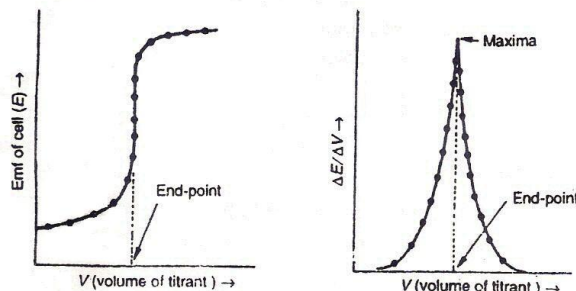
The electrode reaction is



When the concentration of  $\text{M}^{n+}$  ion changes, the electrode potential also changes correspondingly. The change in electrode potential can be measured potentiometrically by coupling the indicator electrode (working electrode) with standard electrode (reference electrode).

$$E_{\text{cell}} = E^{\circ}_{\text{cell}} + \frac{0.0591}{n} \log [M^{n+}]$$

Thus potentiometric titration involves the measurement of EMF between reference electrode and indicator electrode, with the addition of the titrants. In almost each type of potentiometric titrations, there is a sudden change of potential near the end point. This change of potential is measured which gives the end point of the titration. From the EMF values and average volume of the titrants, the end point of the titration can be calculated. The change in EMF of the cell is small at initial stages. But at the end point, the change in the EMF is very sharp. A graph is plotted between the average volume of titrant and  $\Delta E / \Delta V$ . The maxima of the curve give the end point.



**Fig 1.15 Potentiometric curves**

### 1.10.1 TYPES OF POTENTIOMETRIC TITRATIONS

- Acid-Base Titration
- Redox Titration
- Precipitation Titration

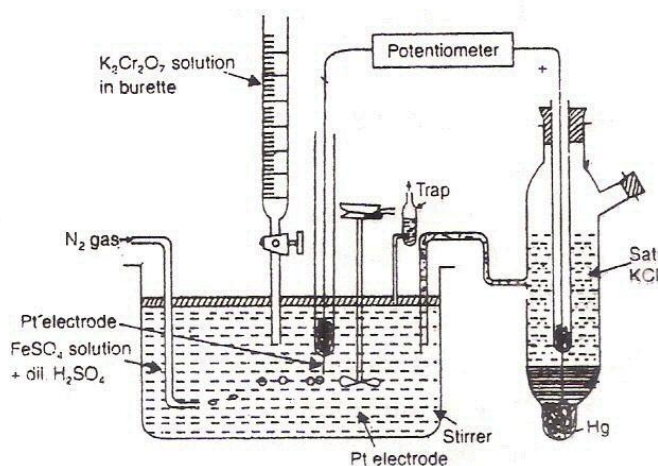
### 1.10.2 REDOX TITRATION ( $\text{FeSO}_4$ vs $\text{K}_2\text{Cr}_2\text{O}_7$ )

Titration involving oxidizing agents like  $\text{K}_2\text{Cr}_2\text{O}_7$  or  $\text{KMnO}_4$  and reducing agents like ferrous sulphate can be followed potentiometrically by using platinum electrode as indicator electrode.

**EXAMPLE:**

|                     |  |
|---------------------|--|
| Indicator Electrode | Platinum electrode   |
| Reference Electrode | Saturated Calomel electrode  |
| Pipette Solution    | 20ml of ferrous ion solution + 20ml of dilute H <sub>2</sub> SO <sub>4</sub>           |
| Burette Solution    | Potassium dichromate , K <sub>2</sub> Cr <sub>2</sub> O <sub>7</sub>                   |
| Cell representation | Hg,Hg <sub>2</sub> Cl <sub>2</sub> (s),KCl    Fe <sup>3+</sup> / Fe <sup>2+</sup> / Pt |

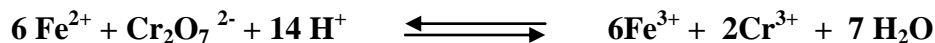
The apparatus used for the titration of ferrous salt with acidified K<sub>2</sub>Cr<sub>2</sub>O<sub>7</sub> is given below:



**Fig 1.16 Potentiometric Redox Titration**

Known amount of ferrous sulphate solution is taken in a beaker and the indicator electrode (platinum electrode) is inserted in it. It is then connected to a reference electrode (saturated calomel electrode) to form a galvanic cell. The cell is then connected to the potentiometer and its  $E_{\text{cell}}$  is determined.

When a solution of ferrous ion is titrated with a solution of K<sub>2</sub>Cr<sub>2</sub>O<sub>7</sub>, the following reaction will take place:



Depending on the ratio between the concentration of oxidation and reduction species, the potential of the cell is varied according to the following equation:

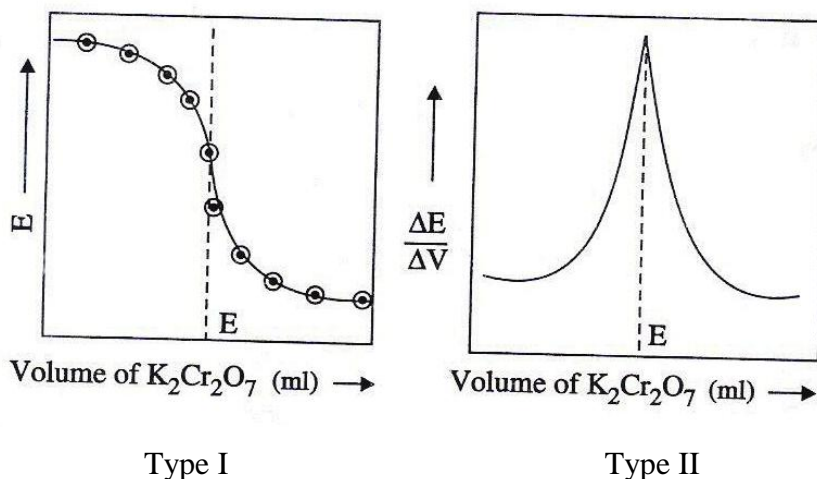
$$E_{\text{cell}} = E^{\circ}_{\text{Fe}^{3+}/\text{Fe}^{2+}} - \frac{0.0591}{n} \log \frac{[\text{Fe}^{3+}]}{[\text{Fe}^{2+}]} \dots\dots\dots(1)$$

$$E_{\text{cell}} = E^{\circ}_{\text{Cr}^{3+}/\text{Cr}_2\text{O}_7^{2-}} - \frac{0.0591}{n} \log \frac{[\text{Cr}^{3+}]}{[\text{Cr}_2\text{O}_7^{2-}]} \dots\dots\dots(2)$$

During the titration when  $\text{K}_2\text{Cr}_2\text{O}_7$  is added, concentration of ferric ion  $[\text{Fe}^{3+}]$  increases which in turn gradually increases the potential. Near the end point, the entire  $[\text{Fe}^{2+}]$  becomes  $[\text{Fe}^{3+}]$ , so the potential of the system is determined by the equation (1) till the end point.

After the end point, further addition of  $\text{K}_2\text{Cr}_2\text{O}_7$  brings in the existence of  $\text{Cr}^{6+} - \text{Cr}^{3+}$  at platinum electrode. A sharp change of potential is expected at the vicinity of the electrode. The potential is determined by equation (2).

When EMF is plotted against the volume of  $\text{K}_2\text{Cr}_2\text{O}_7$  added, a curve of Type I is obtained. Generally, in this S-shaped curve the end point is located on the sharp rising part of the curve. A more accurate end point can be obtained by plotting a graph between  $\Delta E/\Delta V$  against volume of  $\text{K}_2\text{Cr}_2\text{O}_7$  (Type II). The resulting curve shows a sudden and maximum rise at the equivalence point which is the end point.



**Fig 1.17  $E_{\text{cell}}$  vs Volume of  $\text{K}_2\text{Cr}_2\text{O}_7$**



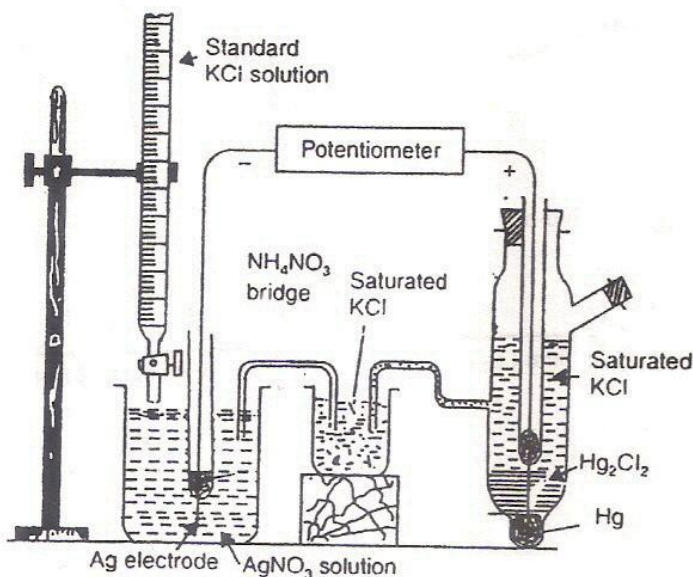
### 1.10.3 PRECIPITATION TITRATION ( $\text{AgNO}_3$ vs $\text{KCl}$ )

#### EXAMPLE:

|                     |  |
|---------------------|--|
| Indicator Electrode | Silver/Silver Chloride electrode   |
| Reference Electrode | Saturated Calomel electrode  |
| Pipette Solution    | 20ml of chloride ion solution  |
| Burette Solution    | Silver nitrate ( $\text{AgNO}_3$ ) solution                                      |
| Cell representation | $\text{Ag}/\text{Ag}^+ \parallel \text{Hg}_2\text{Cl}_2, \text{Cl}^-, \text{Hg}$ |

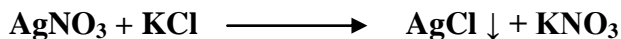
Known amount of silver nitrate solution is taken in a beaker and the indicator electrode (silver-silver ion electrode) is inserted in it. It is then connected to a reference electrode (saturated calomel electrode) to form a galvanic cell. The cell is then connected to the potentiometer and its  $E_{\text{cell}}$  is determined.

The apparatus used for the titration of silver nitrate with  $\text{KCl}$  is given below:



**Fig 1.18 Potentiometric precipitation titration**

When silver nitrate solution is titrated against the standard  $\text{KCl}$  solution, taken in the burette, the concentration of the silver ion decreases due to the formation of  $\text{AgCl}$  precipitate.



As the salt is sparingly soluble, the concentration of  $\text{Ag}^+$  ion in solution progressively increases and soon it reaches a maximum value. Hence the EMF of the cell also increases with the addition of  $\text{AgNO}_3$  solution.

At the end point, once all the chloride ions are precipitated, excess addition of  $\text{AgNO}_3$  rises the concentration of silver ion in solution which in turn raises the EMF very rapidly. After the end point there is no noticeable change in the potential.

When the EMF is plotted against the volume of KCl, a curve of Type I is obtained. The end point is the point, where the slope of the curve is maximum. To obtain more accurate end point, another graph is drawn by plotting  $\Delta E/\Delta V$  against volume of KCl. The resulting curve shows a sudden maximum rise at the equivalent point, which is the end point.

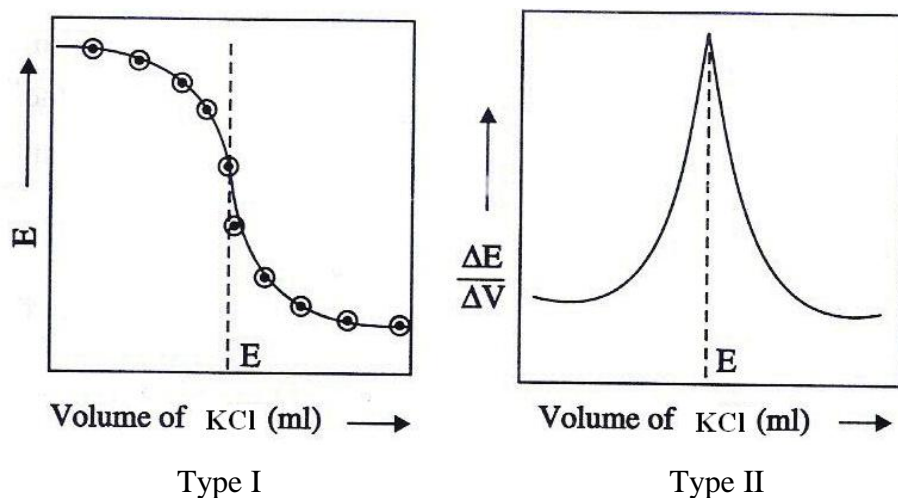


Fig 1.19  $E_{\text{cell}}$  vs Volume of KCl

#### 1.10.4 ADVANTAGES OF POTENTIOMETRIC TITRATIONS

- The method is applicable even for coloured solutions.
- The end point is more accurate.
- Even very dilute solutions can be titrated with accuracy.
- Two or more components present in a solution can be estimated by single titration.
- The apparatus required is cheap and easily available.

## 1.11 CONDUCTOMETRIC TITRATIONS

### PRINCIPLE:

Conductometric titration is a volumetric method based on the measurement of conductance of the solution during the titration.

The conductance of a solution depends on:

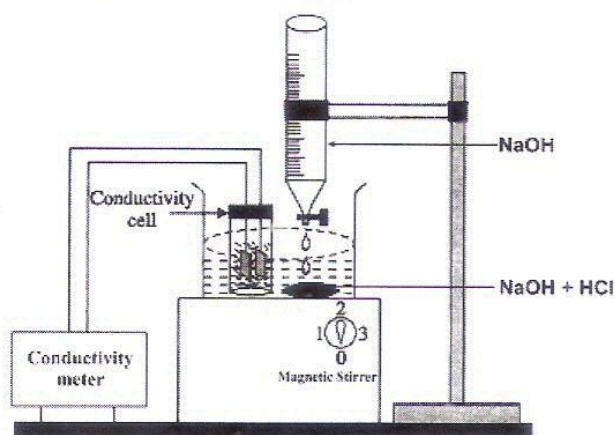
- The number and charge on the free ions
- The mobility of the ions

### 1.11.1 TYPES OF CONDUCTOMETRIC TITRATIONS

- Acid-Base titrations
- Precipitation titrations
- Replacement titrations
- Redox titrations
- Complexometric titrations

### 1.11.2 ACID-BASE TITRATIONS

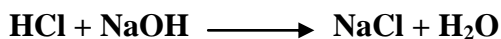
#### Titration of Strong acid vs Strong base (HCl vs NaOH)



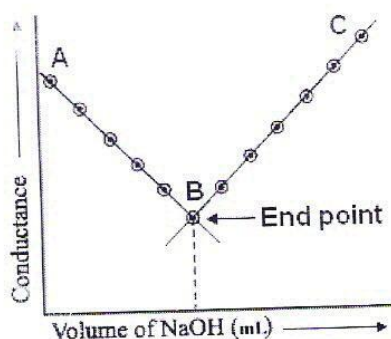
**Fig 1.20 Conductometric acid-base titration**

A known amount of HCl solution is taken in a beaker and a conductivity cell is then dipped in it. Standard NaOH is taken in the burette. Initially the conductivity of the HCl is high due to

the presence of high mobility of  $H^+$  ions. As the NaOH is added gradually, conductance value decreases until the acid has been completely neutralized. This is due to the replacement of fast moving  $H^+$  ions by slow moving  $Na^+$  ions which results in the formation of undissociated water molecules and NaCl.



After the end point, further addition of NaOH will introduce fast moving  $OH^-$  ions and leads to increase in conductance sharply. After some more amount of NaOH, the titration is stopped. A graph is plotted against volume of NaOH versus conductance. Two linear curves are obtained. The point of intersection is the end point of the titration. This corresponds to the volume of NaOH required for neutralization.



**Fig 1.21 Titration of HCl vs NaOH**

### 1.11.3 ADVANTAGES OF CONDUCTOMETRIC TITRATIONS

- It gives more accurate end point.
- It is used in the case of coloured solutions where colour changes of the indicator are not clear.
- It is also used for the analysis of dilute solutions and weak acids.
- Since the end point is detected graphically, no keen observation is necessary near the end point.

### 1.11.4 DISADVANTAGES OF CONDUCTOMETRIC TITRATIONS

- Only limited number of redox titration can be carried out.
- It becomes less accurate and less satisfactory, when the electrolytic concentration is high.

## **REFERENCES:**

1. Puri and Sharma and Pathania “Physical Chemistry” Vishal Publishing Compasny, Jalandhar.

## **UNIT II – CORROSION AND ITS CONTROL**

### **2.1 INTRODUCTION**

Metals and alloys are generally used as fabrication or construction materials in engineering. If the metal or alloy structures are not properly maintained, they deteriorate slowly by the action of atmospheric gases, moisture and other chemicals. This phenomenon of deterioration or destruction of metals and alloys is known as corrosion.

#### **Definition**

“Corrosion is defined as the gradual destruction or deterioration of metals or alloys by the chemical or electrochemical reaction with its environment.”

#### **Need to study corrosion**

There is an annual loss of crores of rupees due to corrosion of metals and their alloys. For steel, it has been estimated that 25% of production is lost through corrosion. The economic importance of this study can be known from this. Hence, an engineer must be (i) aware of the corrosion problem (ii) understand the mechanism of corrosion (iii) apply his knowledge to control corrosion.

#### **Corrosion in day-to-day life**

The following are some of the examples for corrosions, we see in our day –to-day life.

##### **(1) Rusting of iron**

Iron exposed to the environment forms a brown rust film in the surface. It is a wiped off, the clean metal surface metal becomes visible. After few days, the rust is formed again.

### **(2) Water stored in aluminium vessel**

If water is stored for a long time in an aluminium container, white spots will be present at several places. If these spots are rubbed off, small pits are found.

### **(3) Tarnishing of silver**

Silver ornaments are found to form a black, adherent film on the surface.

### **(4) Copper vessel**

It is found to become dark brown or black in colour.

## **Factors influencing corrosion**

The nature of corrosion depends upon the following factors:

- (i) Structure and composition of the alloy
- (ii) Nature of the environment
- (iii) Environmental conditions such as temperature, pressure, velocity, etc.

## **2.2 CAUSES OF CORROSION**

Metals occur in nature in two different forms.

1. Native state.
2. Combined state.

### **1. Native state**

The metals occur in native (or) free (or) uncombined state are non-reactive with the environment. They are noble metals exist as such in the earth crust. They have very good corrosion resistance. Example : Au,Pt,Ag

### **2. Combined state**

Except noble metals, all other metals are reactive and react with environment and form stable compounds, as their oxides, sulphides, chlorides and carbonates. They exist in their form of stable compounds called ores and minerals.

Examples:  $\text{Fe}_2\text{O}_3$ ,  $\text{ZnO}$ ,  $\text{PbS}$ ,  $\text{CaCO}_3$  etc.,

## **2.3 CONSEQUENCES OF CORROSION**

1. Due to formation of corrosion product over the machinery, the efficiency of the machine gets lost.
2. The products get contaminated due to corrosion.
3. The corroded equipment must be replaced frequently.
4. Plant gets failure due to corrosion.
5. It is necessary for over design to compensate for the corrosion.
6. Corrosion releases toxic products health hazard,

## **2.4 CLASSIFICATION OR THEORIES OF CORROSION**

Based on the environment, corrosion is classified into

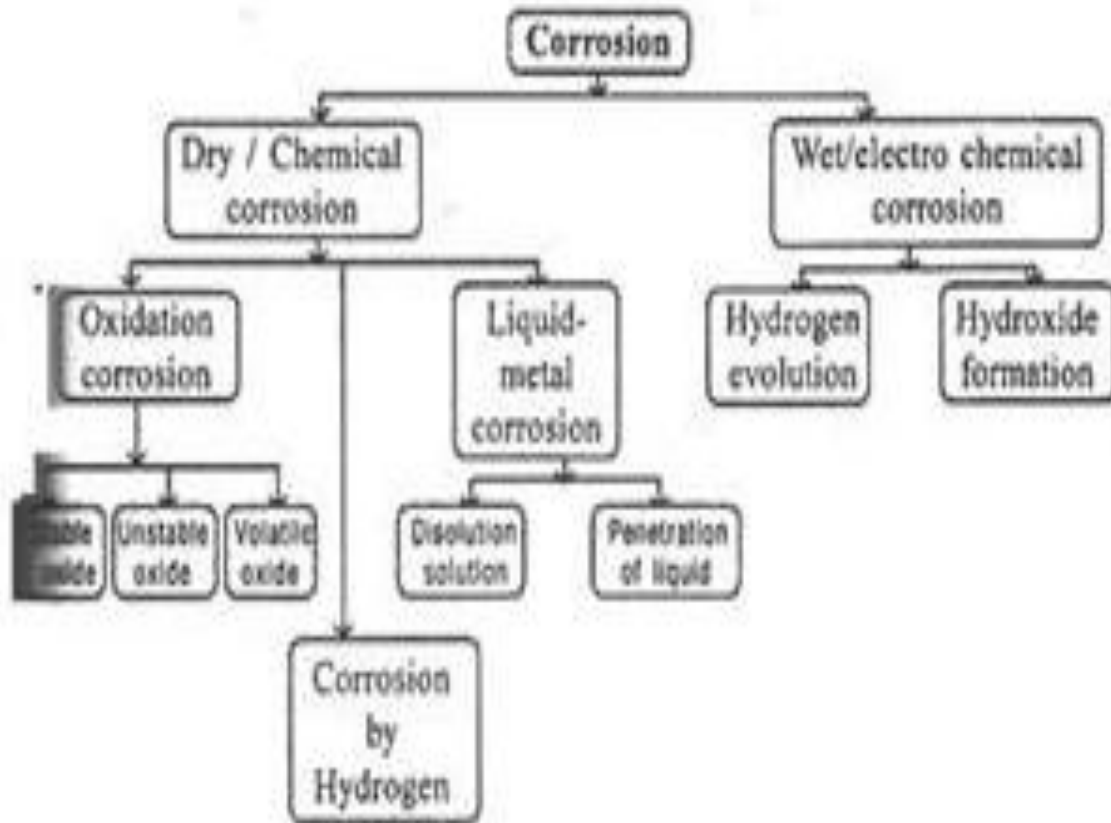
- (i) Dry or Chemical corrosion
- (ii) Wet (or) Electrochemical corrosion

## **2.5 DRY OR CHEMICAL CORROSION**

Dry corrosion is due to the attack of metal surfaces by the atmospheric gases such as oxygen, hydrogen sulphide, sulphur dioxide, nitrogen, etc.

### **TYPES OF DRY CORROSION**

1. Oxidation corrosion (or) corrosion by oxygen.
2. Corrosion by hydrogen
3. Liquid-metal corrosion.



### 2.5.1 OXIDATION CORROSION (OR) CORROSION BY OXYGEN

Oxidation corrosion is brought about by the direct attack of oxygen at low or high temperatures on metal surface in the absence of moisture. Alkali metals (Li, Na, K,, etc.) and alkaline earth metals (Mg, Ca, Sn, etc.) are rapidly oxidised at low temperature. At high temperature, almost all metals (except, Ag, Au and Pt) are oxidized.

#### MECHANISM OF DRY CORROSION

##### Step: 1

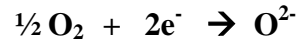
Oxidation occurs first at the surface of the metal resulting in the formation of metal ions ( $M^{2+}$ ), which occurs at the metal / oxide interface.



##### Step: 2



Oxygen changes to ionic form ( $O^{2-}$ ) due to the transfer of electron from metal, which occurs at the oxides film / environment interface



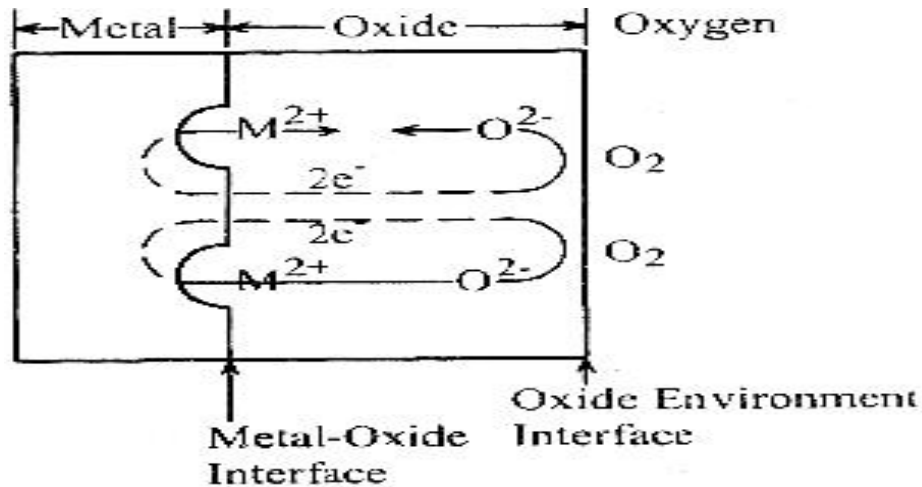
**Step: 3**

Oxide ions react with the metal ion to form the metal oxide film.



**Step: 4**

once the metal surface is converted to a monolayer of metal-oxide, for further corrosion (oxidation) to occur, the metal ion diffuses outward through the metal-oxide barrier. Thus the growth of oxide film commences perpendicular to the metal surface.



**Fig 2.1 Mechanism of oxidation corrosion**

**Nature of oxide film**

The nature of oxide film formed on the metal surface plays an important role in oxidation corrosion

- (i) Stable oxide layer
- (ii) Unstable oxide layer
- (iii) Volatile oxide layer
- (iv) Protective or Non-Protective oxide film

**(i) Stable oxide layer**

A stable oxide layer is a fine grained in structure, and sets adsorbed tightly to the metal surface. Such a layer is impervious in nature and stops further oxygen attack through diffusion. Such a film behaves as a protective coating and no further corrosion can develop.

**Example:** Oxides of Al, Sn, Pb, Cu, etc., are stable oxide layers.

**(ii) Unstable oxide layer**

Unstable oxide layer is mainly produced on the surface of noble metals, which decomposes back into the metal and oxygen



**Example:** Oxides of Pt, Ag, etc., are unstable oxide layers.

**(iii) Volatile oxide layer**

The oxide layer volatilizes as soon as it is formed, leaving the metal surface for further corrosion.

**Example:** Molybdenum oxide (MoO<sub>3</sub>) is volatile,

**(iv) Protective or Non-Protective oxide film (Pilling-Bedworth rule)**

**Pilling-Bedworth ratio**

The ratio of the volume of the oxide formed to the volume of the metal consumed is called “Pilling-Bedworth ratio”

(a) According to Pilling-Bed worth rule, if the volume of the oxide layer formed is less than the volume of the metal, the oxide layer is porous and non-protective.

Example:

The volume of oxides of alkali and alkaline earth metals such as Na, Mg, Ca, etc., is less than the volume of the metal consumed, Hence the oxide layer formed is porous and non-protective,

(b) On the other hand, if the volume of the oxide layer formed is greater than the volume of the metal, the oxide layer is non-porous and protective.

Example:

The volume of oxides of heavy metals such as Pb, Sn, etc., is greater than the volume of the metal. Hence the oxide layer formed is non-porous and protective.

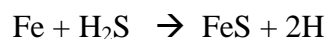
## 2.5.2 CORROSION BY HYDROGEN

Step:1 Hydrogen embrittlement (at ordinary temperature)

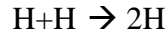
Step:2 Decarburisation (at higher temperature)

**Step:1 Hydrogen embrittlement (at ordinary temperature)**

When metals contact to H<sub>2</sub>S at ordinary temperature causes evolution of atomic hydrogen.



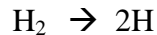
This atomic hydrogen diffuses readily into the metal and collects in the voids, where it recombines to form molecular hydrogen.



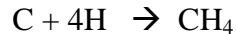
Collections of these hydrogen gases in the voids develop very high pressure, which causes cracks and blisters on metal. This process is called hydrogen embrittlement.

### **Step:2 Decarburisation (at higher temperature)**

At higher temperature atomic hydrogen is formed by the thermal dissociation of molecular hydrogen.



When steel is exposed to this environment, the atomic hydrogen readily combines with carbon of steel and produces methane gas.



Collection of these gases in the voids develops very high pressure, which causes cracking.

**Thus the process of decrease in carbon content in steel is termed as “decarburization” of steel.**

### **2.5.3 LIQUID-METAL CORROSION**

This is due to the chemical action of flowing liquid metal at higher temperature.

- (i) Either dissolution of a solid metal by a liquid metal
- (ii) Liquid metal may penetrate into the solid metal.

### **2.6 WET OR ELECTRO-CHEMICAL CORROSION**

Wet corrosion occurs under the following conditions.

- (i) When two dissimilar metals or alloys are in contact with each other in the presence of an aqueous solution or moisture.
- (ii) When a metal is exposed to varying concentration of oxygen or any electrolyte.

### **MECHANISM OF WET CORROSION**

Under the above conditions, one part of the metal becomes anode and another part becomes cathode.

- (i) At anode

In anodic part, oxidation (or) dissolution of metal occurs

- (ii) At cathode

In cathodic part reduction reaction occurs, which depends on nature of the corrosive environment

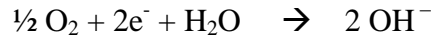
- (a) Acidic environment
- (b) Neutral environment

**(a) Acidic environment**

If the corrosive environment is acidic, hydrogen evolution occurs at cathodic part.

**(b) Neutral environment**

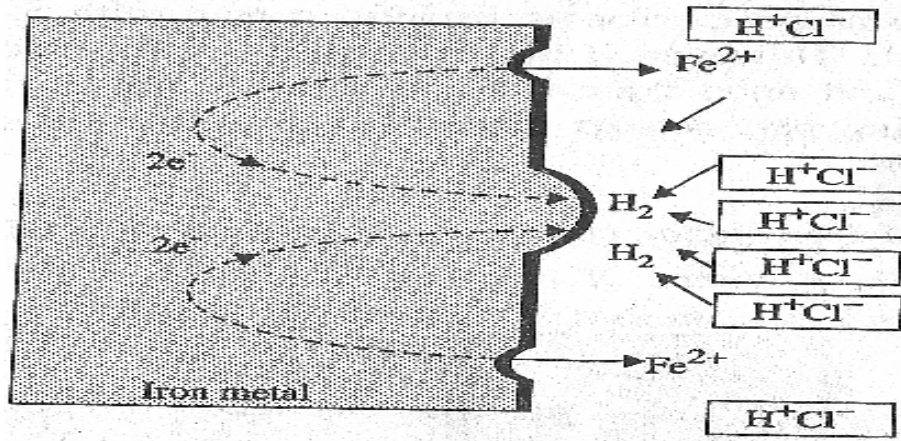
If the corrosive environment is slightly alkaline (or) neutral, hydroxide ion forms at cathodic part.



Thus, the metal ions (from anodic part) and non-metallic ions (from cathodic part) diffuse towards each other through conducting medium and form a corrosion product between anode and cathode.

**(a) Hydrogen evolution type corrosion**

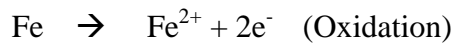
“All metals above hydrogen in the electrochemical series have a tendency to get dissolved in acidic solution with simultaneous evolution of hydrogen gas”



**Fig.2.2 Hydrogen evolution type corrosion**

**At anode**

Iron undergoes dissolution to give Fe<sup>2+</sup> ions with the liberation of electrons.



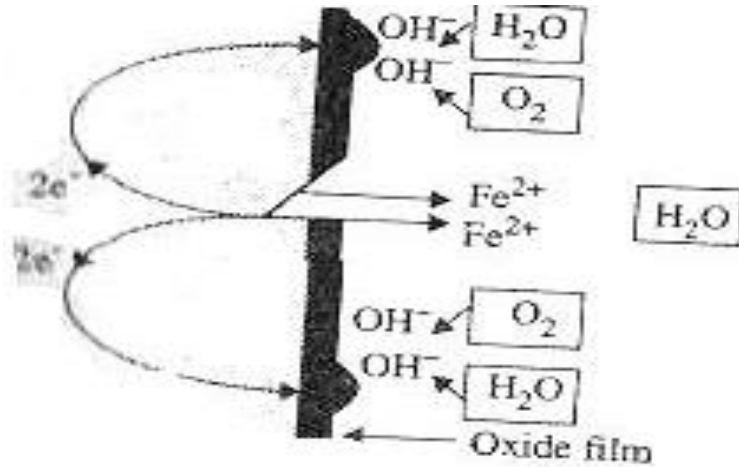
**At cathode**

The liberated electrons flow from anodic to cathodic part, where H<sup>+</sup> ions get reduced to H<sub>2</sub>.



**(b) Absorption of oxygen (or) Formation of hydroxide ion type corrosion**

The surface of iron is usually, coated with a thin film of iron oxide, however, if the oxide film develops, some crack will come and anodic areas are created on the surface while the remaining part acts as cathode.



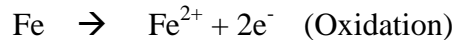
**Fig. 2.3 Absorption of oxygen type corrosion**

**Example**

When iron metal contacts with a neutral solution of an electrolyte in presence of oxygen, OH<sup>-</sup> ions are formed

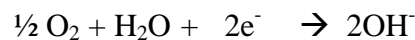
**At anode** (oxidation)

Iron dissolves as Fe<sup>2+</sup> with the liberation of electrons.



**At cathode**

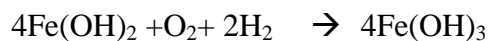
The liberated electrons flow from anodic to cathodic part through metal, where the electrons are taken up by the dissolved oxygen to form OH<sup>-</sup> ions.



**Thus, the net corrosion reaction is**



If enough O<sub>2</sub> is present Fe(OH)<sub>2</sub> is easily oxidised to Fe(OH)<sub>3</sub>, a rust (Fe<sub>2</sub>O<sub>3</sub> . H<sub>2</sub>O).



**TABLE 2.1 DIFFERENCE BETWEEN CHEMICAL AND ELECTROCHEMICAL CORROSION**

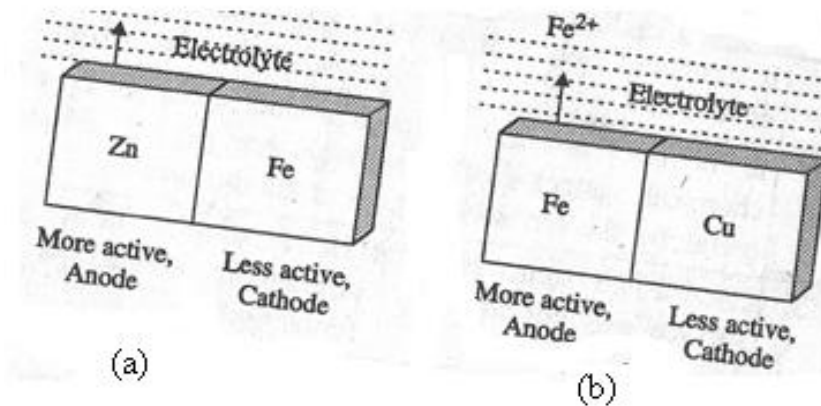
| <b>S.No.</b> | <b>Chemical corrosion</b>  | <b>Electrochemical corrosion</b>  |
|--------------|--|---|
| <b>1.</b>    | It occurs only in dry condition.   | It occurs in presence of moisture or electrolyte.                       |
| <b>2.</b>    | It is due to the direct chemical attack of the metal by the environment. | It is due to the set up of a large number of cathodic and anodic areas. |
| <b>3.</b>    | Even a homogeneous metal surface gets corroded.                          | Heterogeneous surface (or) Bimetallic contact is the condition.         |
| <b>4.</b>    | Corrosion products accumulate in the same place, where corrosion occurs. | Corrosion occurs at the anode, while products formed elsewhere.         |
| <b>5.</b>    | Chemical corrosion is self-controlled                                    | It is continuous process.   |

### **2.6.1 TYPES OF ELECTROCHEMICAL CORROSION**

#### **I. Galvanic corrosion**

When two different metals are in contact with each other in presence of an aqueous solution or moisture, galvanic corrosion occurs.

Here, the more active metal (with more negative electrode potential) acts as anode and the less active metal (with less negative electrode potential) acts as cathode.



**Fig.2.4 (a) & (b) Galvanic corrosion**

Fig. 2.4 (a) represents Zn - Fe couple, in which zinc (more active or higher in emf series) dissolves in preference to iron (less active metal) i.e., Zn acts as anode and undergoes corrosion and Fe acts as cathode.

Fig.2.4 (b) represents Fe - Cu couple, in which iron (more active, when compared to Cu) dissolves in preference to copper (less active) i.e., Fe acts as anode and undergoes Corrosion and Cu acts as cathode.

### **Example for Galvanic Corrosion**

#### **(i) Steel screw in a brass marine hardware corrodes**

This is due to galvanic corrosion. Iron (higher position in electrochemical series) becomes anodic and is attacked and corroded, while brass (lower in electrochemical series) acts as cathodic and is not attacked.

#### **(ii) Bolt and Nut made of the same metal is preferred**

It is preferred in practice, because galvanic corrosion is avoided due to homogeneous metals (no anodic and cathodic part)

### **Prevention**

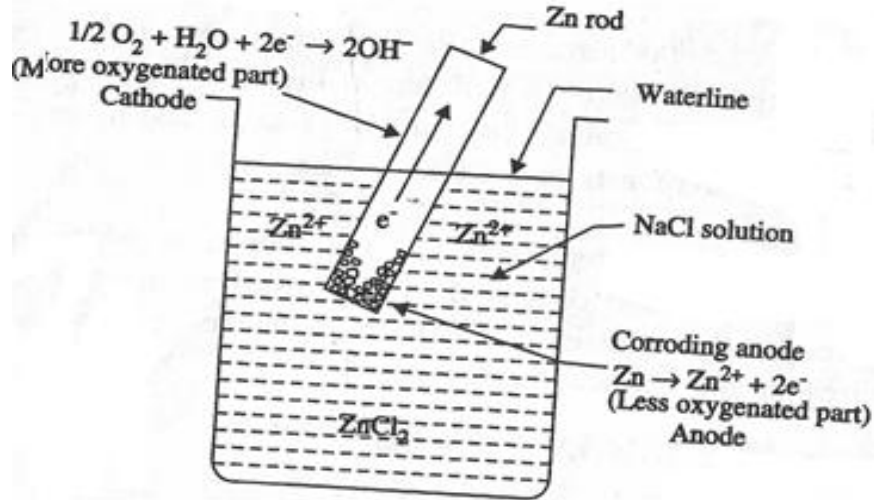
Galvanic corrosion can be minimised by providing an insulating material between the two metals.

## **2. DIFFERENTIAL AERATION (OR) CONCENTRATION CELL CORROSION**

This type of corrosion occurs when a metal is exposed to varying concentration of oxygen or any electrolyte on the surface of the base metal.

**Example**

Metals partially immersed in water (or) conducting solution (called water line corrosion).



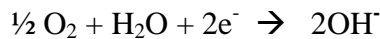
**Fig.2.5 Differential aeration corrosion**

If a metal is partially immersed in a conducting Solution (Fig.2.6) the metal part above the Solution is more aerated and hence become cathodic. On the other hand, the metal part inside the Solution is less aerated and thus, become anodic and suffers corrosion

**At anode** (less aerated) corrosion occurs



**At cathode** (more aerated part) OH<sup>-</sup> ions are produced



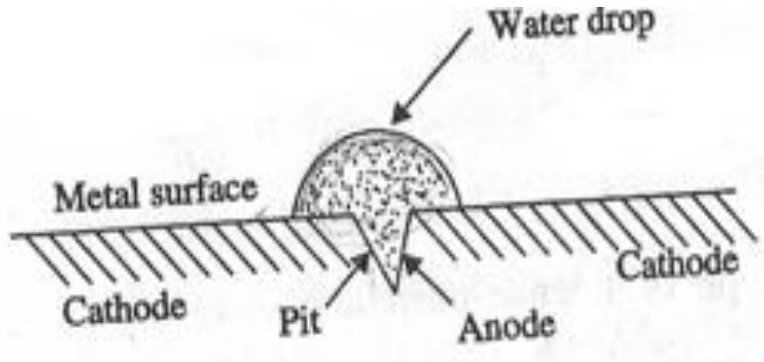
**EXAMPLES FOR DIFFERENTIAL AERATION CORROSION**

- (a) Pitting (or) localized corrosion
- (b) Crevice corrosion.
- (c) Pipeline corrosion.
- (d) Corrosion on wire fence

**(a) Pitting corrosion.**



Pitting is a localized attack, resulting in the formation of a hole around which the metal is relatively unattached.



**Fig.2.6 Pitting corrosion**

**Example:** Metal area covered by a drop of water, sand, dust, scale, etc.

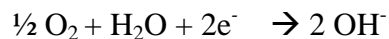
Let us consider a drop of water or aqueous NaCl resting on a metal surface. The area covered by the drop of water acts as an anode due to less oxygen concentration and suffers corrosion. The uncovered area (freely exposed to air) acts as a cathode due to high oxygen concentration.

The rate of corrosion will be more, when the area of cathode is larger and the area of anode is smaller. Therefore, more and more material is removed from the same spot. Thus a small hole or pit is formed on the surface of the metal.

**At anode :** Iron is oxidised to  $\text{Fe}^{2+}$  ions



**At cathode :** Oxygen is converted to  $\text{OH}^{-}$  ions.



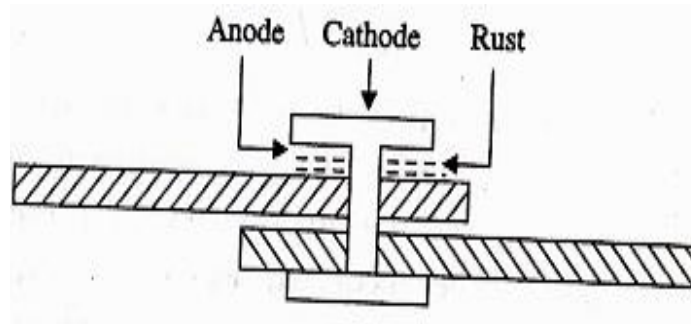
**Net reaction is**



This type of intense corrosion is called pitting.

### **(b) Crevice corrosion**

If a crevice between different metallic objects or between metal and non metallic material is in contact with liquids, the crevice becomes the anodic region and suffers corrosion. This is due to less oxygen with crevice area. The exposed areas act as the cathode

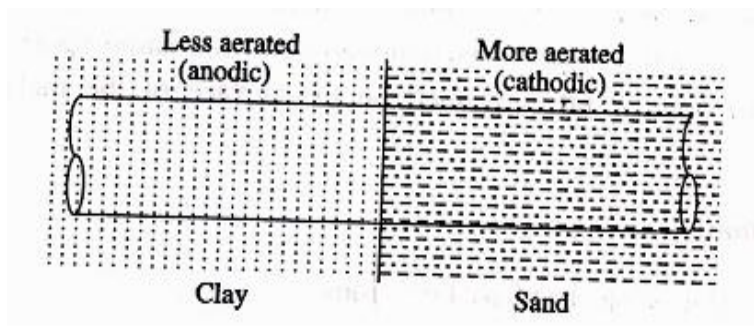


**Fig.2.7 Crevice corrosion**

**c) Pipeline corrosion**

Differential aeration corrosion may also occur in different parts of pipeline.

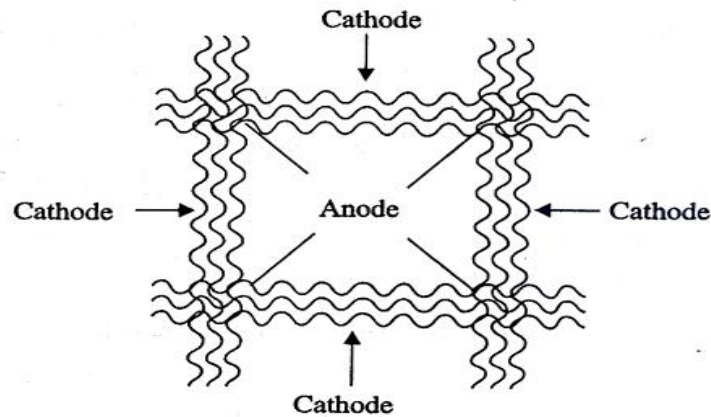
Buried pipelines or cables passing from one type of soil to another say, from clay (less aerated) to sand (more aerated) may get corroded due to differential aeration.



**Fig 2.8 Pipeline corrosion**

**(d) Corrosion on wire-fence**

It shows a wire fence in which the areas where wires cross are less aerated than the rest of the fence and wire corrosion occurs at the wire crossings, which are anodic.



**Fig 2.9 Corrosion on wire fence**

### Other examples for differential aeration corrosion

(i) Corrosion occurring under metal washers, where oxygen cannot diffuse easily.

(ii) Lead pipeline passing through clay to cinders undergo corrosion, Since the pipeline under cinders is more aerated, it gets corroded easily.

## 2.7 FACTORS INFLUENCING THE RATE OF CORROSION

The rate and extent of corrosion mainly depends on

(i) Nature of the metal.

(ii) Nature of the environment.

### 2.7.1 NATURE OF THE METAL

#### (a) Position in emf series

The extent of corrosion depends on the position of the metal in the emf series. Metals above the hydrogen in emf series get corroded vigorously. Lower the reduction potential, greater is the rate of corrosion. When two metals are in electrical contact, the more active metal (or the metal having high negative reduction potential) undergoes corrosion.

The rate and severity of corrosion depends on the difference in their positions in the emf series. Greater the difference faster is the corrosion rate.

#### (b) Relative areas of the anode and cathode

The rate of corrosion will be more, when the cathodic area is larger. When the cathodic area is larger, the demand for electrons will be more and this results in an increased rate of corrosion (dissolution) of metals at anodic area.

#### (c) Purity of the metal

The 100% pure metal will not undergo any type of corrosion. But, the presence of impurities in a metal creates heterogeneity and thus galvanic cells are set up with distinct anodic and cathodic area in the metal. Higher the percentage of impurity, faster is the rate of corrosion of the anodic metal.

The effect of impurities on the rate of corrosion of zinc is given below

|                 |        |       |       |
|-----------------|--------|-------|-------|
| %purity of Zinc | 99.999 | 99.99 | 99.95 |
| Corrosion rate  | 1      | 2650  | 5000  |

#### **(d) Over voltage or over potential**

The over voltage of a metal in the corrosive environment is inversely proportional to corrosion rate.

#### **Example**

The normal hydrogen over voltage of zinc metal, when it is dipped in 1 M  $\text{H}_2\text{SO}_4$ , is 0.7 volt. Here the rate of corrosion is low. By adding small amount of impurity like  $\text{CuSO}_4$  to  $\text{H}_2\text{SO}_4$ , the hydrogen over voltage is reduced to 0.33. This results in increased rate of corrosion of zinc metal.

#### **e) Nature of the surface film**

The nature of the oxide film formed on the metal surface decides the extent of corrosion which can be decided by pilling-Bedworth rule

(i) In the case of alkali and alkaline earth metals such as Mg, Ca, etc. form oxide, whose volume is less than the volume of the metal. Hence the oxide film will be porous and non-protective and bring about further corrosion.

(ii) But in heavy metals like Al, Cr, etc. form oxide, whose volume is greater than that of the metal. Hence the oxide film will be non-porous and protective and prevents further corrosion.

#### **(f) Nature of the corrosion product**

If the corrosion product is soluble in the corroding medium, the corrosion rate will be faster. Similarly, if the corrosion product is volatile (like  $\text{MoO}_3$  on Mo surface) the corrosion rate will be faster.

### **2.7.2 NATURE OF THE ENVIRONMENT**

#### **(a) Temperature**

The rate of corrosion is directly proportional to temperature. This is because, the rate of chemical reaction and the rate of diffusion of the ions increases with rise in temperature. Hence the rate of corrosion increases with temperature

#### **b) Humidity**

The rate of corrosion will be more, when the humidity in the environment is high. The moisture acts as a solvent for the oxygen in the air to produce the electrolyte, which is essential for setting up a corrosion cell.

#### **(c) Presence of corrosive gases**

The acidic gases like,  $\text{CO}_2$ ,  $\text{SO}_2$ ,  $\text{H}_2\text{S}$  and fumes of  $\text{HCl}$ ,  $\text{H}_2\text{SO}_4$ , etc., produce electrolytes, which are acidic and increases the electrochemical corrosion.

**(d) Presence of suspended particles**

Particles like, NaCl,  $(\text{NH}_4)_2 \text{SO}_4$  along with moisture act as powerful electrolytes and thus accelerate the electrochemical corrosion.

**e) Effect of pH**

The possibility of corrosion with respect to pH of the electrolytic solution and the electrode potential of the metal is correlated with the help of a pourbaix diagram.

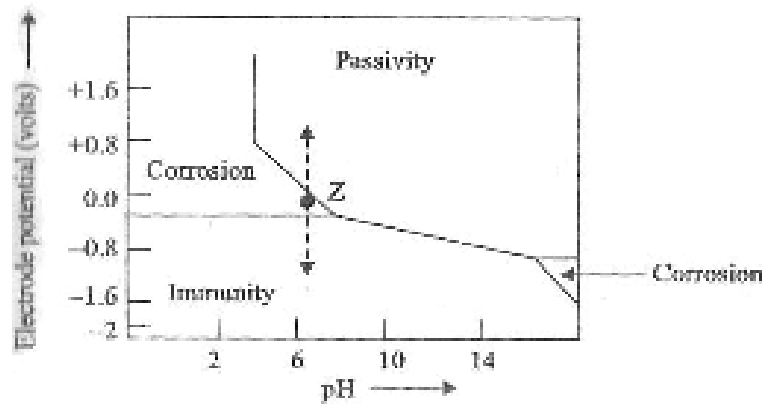
The rate of corrosion can also be reduced by increasing the pH of the solution by adding alkali. Thus the rate of corrosion will be maximum when the corrosive environment is acidic. i.e. pH is less than 7.

The pourbaix diagram for iron in water is shown in fig. 2.11. It shows clearly the zones of corrosion, immunity and passivity. In the diagram, 'Z' is the point where  $\text{pH} = 7$  and the electrode potential = 0.4 V. It is present in the corrosion Zone. This clearly shows that iron rusts in water under those conditions. In actual practice, it is observed to be true.

From the diagram (Fig. 2.11) it is clear that the rate of corrosion can be altered by shifting the point 'Z' into immunity or passivity regions. The iron will be immune to corrosion, if the potential is changed to about -0.8 V by applying external current. On the other hand, the rate of corrosion of iron can also be reduced by moving into the passivity region by applying positive potential.

The diagram clearly indicates that the rate of corrosion can also be reduced by increasing the pH of the solution by adding alkali.

Thus the rate of corrosion will be maximum when the corrosive environment is acidic, i.e. pH is less than 7.



**Fig.2.10 Pourbaix diagram**

## 2.8 CORROSION CONTROL

The rate of corrosion can be controlled by either modifying the metal or the environment.

### 2.8.1 CONTROL OF CORROSION BY MODIFYING THE METAL

#### 1. By selection of the metal

Selection of right type of metal is the main factor for corrosion control. Thus, noble metals are used in ornaments and in surgical instruments, as they are most immune to corrosion.

#### 2. By using pure metal

Pure metals have higher corrosion resistance. Even a small amount of impurity may lead to severe corrosion.

#### 3. By alloying

Corrosion resistance of many metals can be improved by alloying. For example, stainless steel containing chromium produces a coherent oxide film, which protects the steel from further attack.

#### 4. By proper design

Some of the important rules for designing, which must be observed are given below.

##### (i) Avoid galvanic corrosion

If two different metals are joined, galvanic corrosion will occur. In such a case galvanic corrosion is prevented by

- Selecting the metals as close as possible in the electrochemical series.
- Providing smaller area for cathode and larger area for anode.
- Inserting an insulating material between the two metals

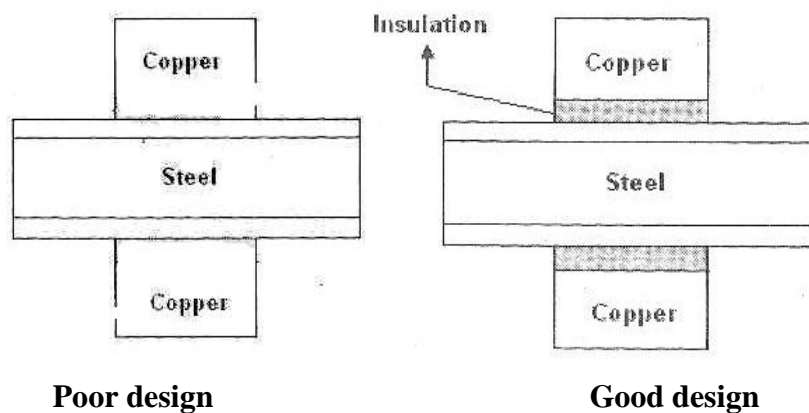


Fig.2.11 Insulation avoids galvanic corrosion

### (ii) Drainage affects corrosion

Tanks and other containers must be designed in such a way that, the whole of the liquid should be drained off completely.

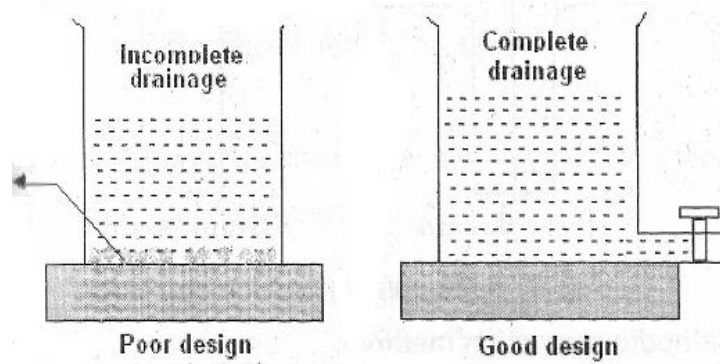


Fig.2.12 Drainage affects corrosion

### (iii) Avoid sharp corners and bends

Sharp corners or edges should always be avoided, and hence erosion corrosion can be avoided by smooth corners or curved pipe bends.

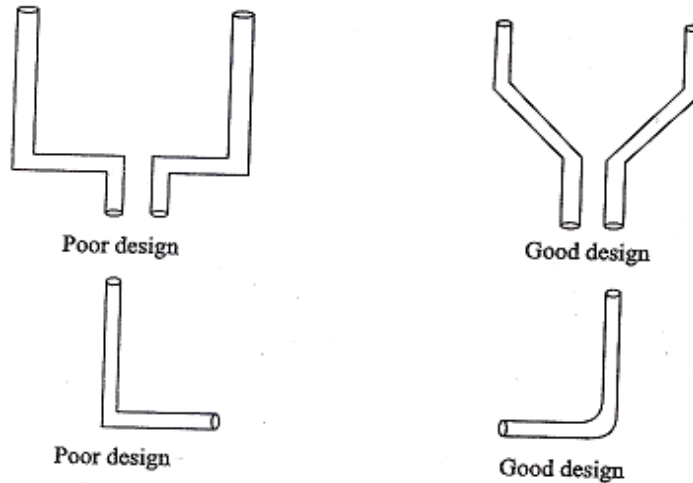
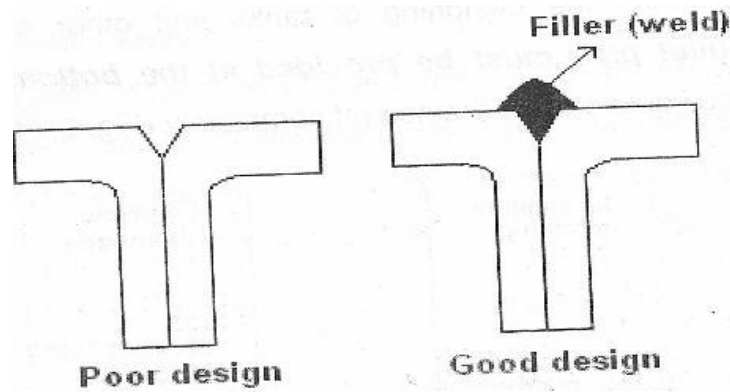


Fig.2.13 Corrosion prevention using curved pipeline

### (iv) Avoid crevices

Crevices allow moisture and dirt, which results in increased electrochemical corrosion. This can be prevented by filling the crevices with a filler.

**Example:** Riveted joints produce crevice corrosion, so welded joints are preferred.



**Fig. 2.14 Minimizing crevice corrosion**

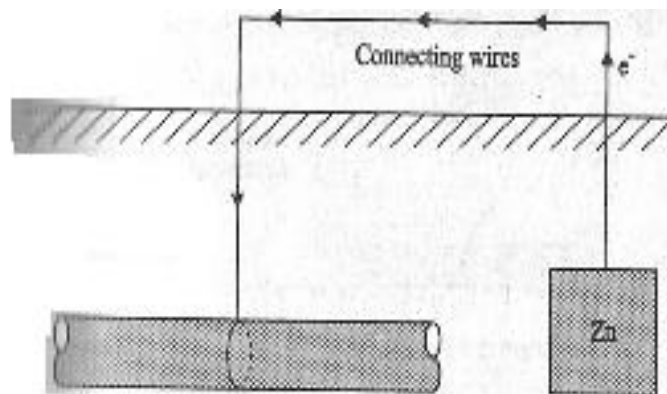
#### **4. By cathodic protection**

The principle involved in the cathodic protection is to force the metal to behave like a cathode. The important cathodic protections are (i) sacrificial anodic protection. (ii) Impressed current cathodic protection

##### **(i) Sacrificial anodic protection method**

In this method, the metallic structure to be protected is made cathode by connecting it with more active metal (anodic metal) So that all the corrosion will concentrate only on the active metal. The artificially made anode thus gradually gets corroded protecting the original metallic structure. Hence this process is otherwise known as sacrificial anodic protection.

Aluminium, Zinc, Magnesium are used as sacrificial anodes

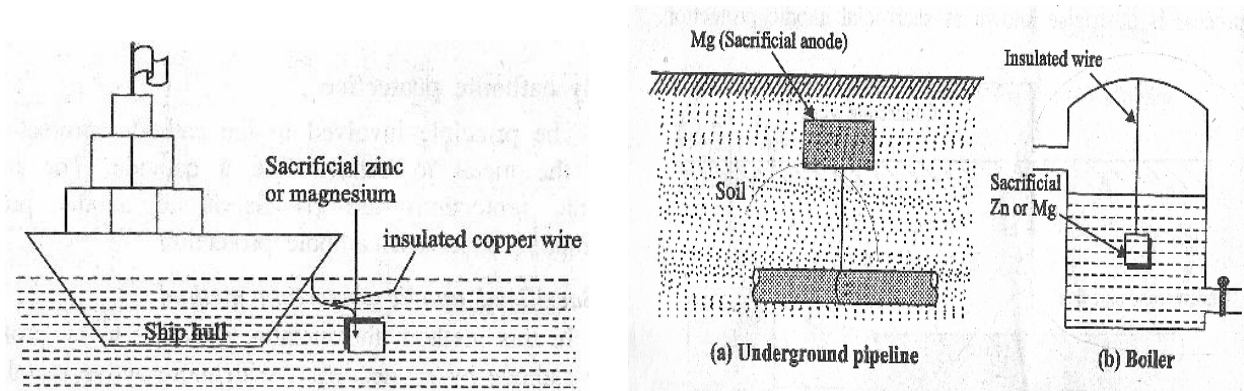


**Fig. 2.15 Sacrificial anodic protection**



## Applications of sacrificial anodic protection

(a) This method is used for the protection of ships and boats. Sheets of Mg or Zn are hung around the hull, of the ship .Zn or Mg will act as anode compared to iron (ship or boat is made of iron), so corrosion concentrates on Zn or Mg. Since they are sacrificed in the process of saving iron they are called sacrificial anodes.



**Fig. 2.16 Sacrificial anodic protection**

(b) Protection of underground pipelines, cables from soil corrosion( Fig.2.16(a) ).

(c) Insertion of Mg Sheets into the domestic water boilers to prevent the formation of rust (fig.2.16(b))

(d) Calcium metal is employed to minimize engine corrosion.

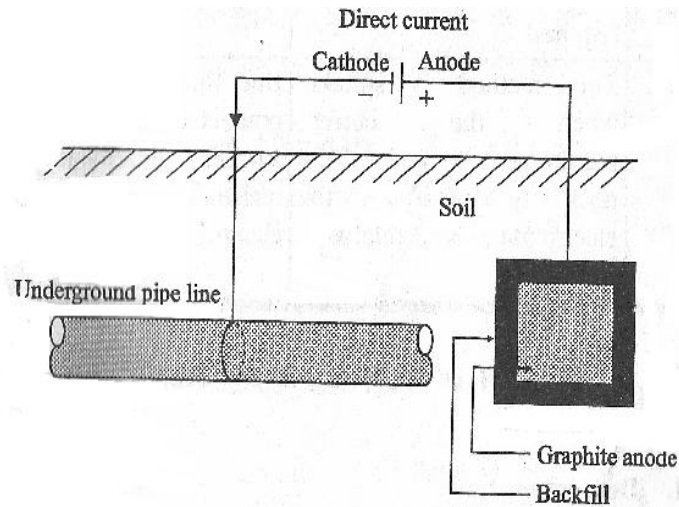
## (ii) Impressed current cathodic protection method

In this method, an impressed current is applied in the opposite direction of the corrosion current to nullify it, and the corroding metal is converted from anode to cathode.

This can be done by connecting negative terminal of the battery to the metallic structure to be protected, and positive terminal of the battery is connected to an inert anode. Inert anodes used for this purpose are graphite, platinised titanium. The anode is buried in a “back fill” (containing mixture of gypsum, coke, breeze, sodium sulphate). The “back fill” provides good electrical contact to anode. (Fig.2.19)

## Applications of impressed current protection

Structures like tanks, pipelines, transmission line towers, underground water pipe lines, oil pipe lines, ships, etc., can be protected by this method.



**Fig 2.17 Impressed current cathodic protection**

**Table 2.2 Comparison of Galvanic method (Sacrificial anode) and Impressed current Cathodic method**

| S.No. | Sacrificial anodic method  | Impressed current method   |
|-------|--|--|
| 1.    | No external power supply is necessary  | External power supply must be present.   |
| 2.    | This method requires periodical replacement of sacrificial anode.  | Here anodes are stable and do not disintegrate   |
| 3.    | Investment is low.   | Investment is more.  |
| 4.    | Soil and microbiological corrosion effects are not taken into account.   | Soil and microbiological corrosion effects are taken into account  |
| 5.    | This is most economical method especially when short-term protection is required.                                | This method is well suited for large structures and long term operations.  |
| 6.    | This method is suitable when the current requirement and the resistivity of the electrolytes are relatively low. | But this method can be practiced even if the current requirement and the resistivity of the electrolytes are high. |

## 2.8.2 CONTROL OF CORROSION BY MODIFYING THE ENVIRONMENT

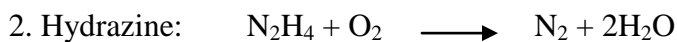
### 1. Deaeration

The presence of increased amount of oxygen is harmful and increases the corrosion rate, Deaeration involves removal of dissolved oxygen by increase of temperature together with mechanical agitation, It also removes dissolved CO<sub>2</sub> of water.

### (2) Deactivation

It is a process of removing dissolved oxygen by adding some chemicals in aqueous solution.

### Examples



### 3. Dehumidification

In this method, moisture from the air is removed by lowering the relative humidity of the surrounding air. This is done by adding silica gel (or) alumina, which adsorbs moisture preferentially on its surface.

### 4. Alkaline neutralization

The acidic character of the corrosive environment (due to presence of H<sub>2</sub>S, HCl, CO<sub>2</sub>, SO<sub>2</sub>, etc) can be neutralized by spraying alkaline neutralizers (like NH<sub>3</sub>, NaOH, lime, etc.)

### 5. Using Corrosion Inhibitors

A corrosion inhibitor is a substance which reduces the corrosion of a metal, when it is added to the corrosive environment.

## 2.9 TYPES OF INHIBITORS

Inhibitors are classified into three types

1. Anodic inhibitors.
2. Cathodic inhibitors.
3. Vapour phase inhibitors.

### 1. Anodic Inhibitors

**Examples:** Chromates, nitrates, phosphates, tungstates or other ions of transition elements with high oxygen content.

Anodic inhibitors are those that prevent the corrosion reaction, occurring at the anode, by forming an insoluble compound with the newly produced metal ions. These precipitates are adsorbed on the metal (anode) surface, forming a protective film and reducing the corrosion rate.

Though this type of control is effective, it may be dangerous, since severe local attack can occur, if some areas are uncovered.

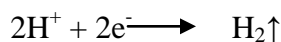
## II. Cathodic Inhibitors

In an electrochemical corrosion, the cathodic reactions are of two types depending upon the environment.

### (a) In an Acidic Solution

**Examples:** Organic inhibitors like amines, mercaptans, heterocyclic nitrogen compounds, thioureas, substituted ureas, heavy metal soaps.

In an acidic solution, the cathodic reaction is evolution of hydrogen i.e.,



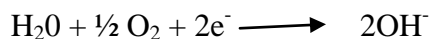
### The corrosion can be reduced in two ways

- (i) By slowing down the diffusion of  $\text{H}^+$  ions to the cathode. This can be done by adding organic inhibitors like amines, pyridines, etc., which are adsorbed at the metal surfaces,
- ii) By increasing the over voltage of hydrogen evolution. This can be done by adding antimony and arsenic oxides, which deposit adherent film of metallic arsenic or antimony at the cathodic areas.

### (b) In a Neutral Solution

**Examples:** Sodium sulphite ( $\text{Na}_2\text{SO}_3$ ), hydrazine ( $\text{N}_2\text{H}_4$ ).

In a neutral solution, the cathodic reaction is



The corrosion can be reduced in two ways.

- (i) By eliminating the oxygen from the neutral solution, there by formation of  $\text{OH}^-$  ions are inhibited. This can be done by adding reducing agents like  $\text{Na}_2\text{SO}_3$ ,  $\text{N}_2\text{H}_4$ , etc.
- (ii) By eliminating the  $\text{OH}^-$  ions from the neutral solution. This can be done by adding Mg, Zn, or Ni salts. These react with  $\text{OH}^-$  ions form insoluble hydroxides which are deposited on the cathode forming more or less impermeable self-barriers.

## III. Vapour phase inhibitors (VPI)

**Examples:** Dicyclohexylammonium nitrate, benzotriazole, etc.

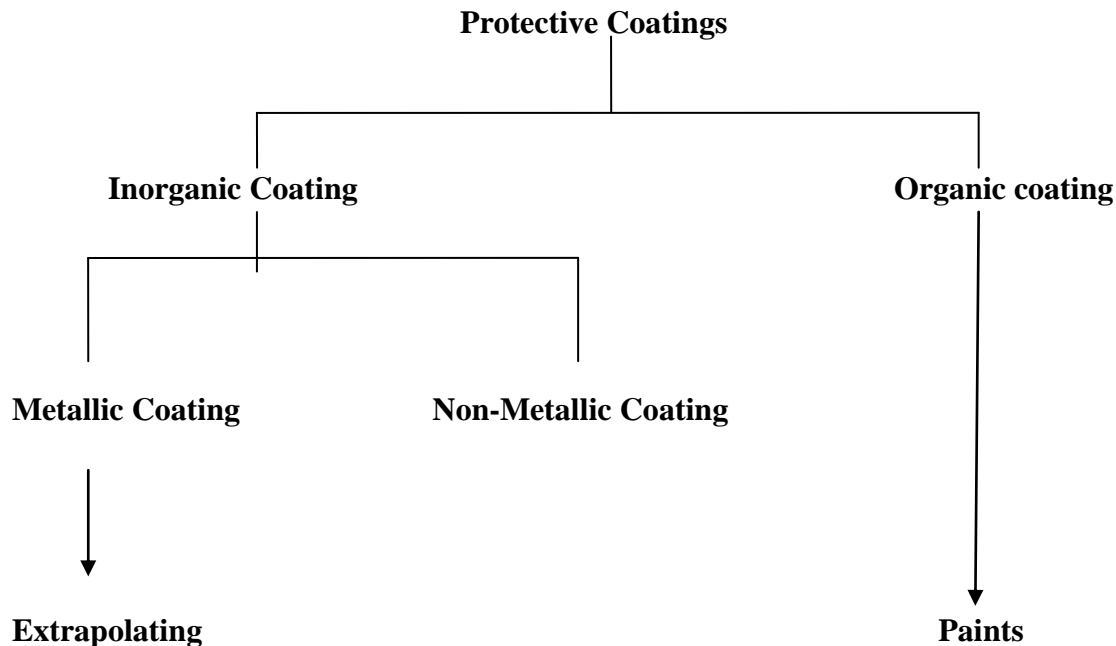
Vapour phase inhibitors are organic inhibitors, which readily vapourise and form a protective layer on the metal surface. VPI are used in the protection of storage containers, packing materials, sophisticated equipments etc.

# PROTECTIVE COATINGS

## 2.10 INTRODUCTION

Protective coatings are used to protect the metals from corrosion, Protective coatings act as a physical barrier between the coated metal surface and the environment. However, they are also used for decoration; they impart some special properties such as hardness, electrical properties, oxidation-resistance and thermal insulating properties to the protected surface.

### Types of Protective Coatings



## 2.11 PAINTS

Paint is a mechanical dispersion of one or more finely divided pigments in a medium (thinner + vehicle). When a paint is applied to a metal surface, the thinner evaporates, while the vehicle undergoes slow oxidation forming a pigmented film.

### 2.11.1 REQUISITES OR CHARACTERISTICS OF A GOOD PAINT

- (i) It should spread easily on the metal surface.
- (ii) It should have high hiding (covering) power.
- (iii) It should not crack on drying.

- (iv) It should adhere well to the surface.
- (v) The colour of the paint should be stable.
- (vi) It should be a corrosion and water resistant.
- (vii) It should give a glossy film.

### 2.11.2 CONSTITUENTS OF PAINT AND THEIR FUNCTIONS

The following ingredients are present in paint.

1. Pigment
2. Vehicle or drying oil
3. Thinners (or) solvents
4. Extenders or fillers
5. Driers

#### 1. Pigments

Pigments are solid and colour producing substances in the paint.

#### Functions

It gives colour and opacity to the film.

It also provides strength to the film.

It protects the film by reflecting the destructive UV rays.

#### Examples:

|                |  |
|----------------|--|
| White pigments | White lead ( $2\text{PbCO}_3 \cdot \text{Pb(OH)}_2$ ).<br>Lithophone (75% $\text{BaSO}_4$ +25% $\text{ZnS}$ ). |
| Black pigments | Lamp black, carbon black.  |
| Red pigments   | Venetian red ( $\text{Fe}_2\text{O}_3$ and $\text{CaSO}_4$ ).<br>Indian red ( $\text{Fe}_2\text{O}_3$ ).       |
| Blue pigments  | Prussian blue $\text{Fe}_4 [ \text{Fe(CN)}_6 ]$ .  |
| Green pigments | Chromium oxide.  |

#### 2. Vehicle or drying oil

This is a non-volatile portion of a medium. This is the film forming constituent of the paint.

These are high molecular weight fatty acids present in vegetable and animal oils.

#### Functions

- (i) They form a protective film by the oxidation and polymerisation of the oil.

- (ii) They hold the pigment particles together on the metal surface.
- (iii) They impart water repellency, toughness and durability to the film.

**Examples:** Linseed oil, dehydrated castor oil.

### **3. Thinners (or) solvents**

This is a volatile portion of a medium. It easily evaporates after application of the paint.

#### **Functions**

- (i) It reduces the viscosity of the paint, so that it can be easily applied on the surface.
- (ii) It dissolves the oil, pigments, etc. and produces a homogeneous mixture.
- (iii) It increases the elasticity of the film.
- (iv) It increases the penetrating power of the vehicle.

**Examples:** Kerosene, turpentine oil

### **4. Extenders or fillers**

These are white (or) colourless pigments.

#### **Functions**

- (i) It reduces the cost of the paint.
- (ii) It retards the settling of the pigment in all paints.
- (iii) It modifies the shades of the pigments.
- (iv) It prevents shrinkage and cracking.

**Examples:** Talc, gypsum, china clay, etc.

### **5. Driers**

These are the substances, used to accelerate the process of drying.

#### **Functions**

- (i) They act as oxygen-carriers (or) catalysts.
- (ii) They provide oxygen, which is essential for oxidation, polymerisation of drying oil.

**Examples:** Metallic soaps, linoleates and resinates of Co, Mn and Pb.

### **6. Plasticisers**

These are chemicals added to the paint to provide elasticity to the film and to prevent cracking of the film. **Examples:** Triphenyl phosphate, tricresyl phosphate, etc.

### **7. Anti-skinning agents**

These are chemicals added to the paint to prevent gelling and skinning of the paint.

**Example :** Polyhydroxy phenol.

## **2.12 METALLIC COATINGS**

### **2.12.1 ELECTROPLATING (OR) ELECTRO-DEPOSITION**

#### **Principle**

Electroplating is the process in which the coating metal is deposited on the base metal by passing a direct current through an electrolytic solution containing the soluble salt of the coating metal.

The base metal to be plated is made cathode of an electrolytic cell, whereas the anode is either made of the coating metal itself or an inert material of good conductivity.

#### **Objectives of Electroplating**

##### **1. On Metals**

- (i) To increase the resistance to Corrosion of the coated metal.
- (ii) To improve the hardness and physical appearance of the article.
- (iii) To increase the decorative and commercial values of the article.
- (iv) To increase resistance to chemical attack.
- (v) To improve the properties of the surface of the article.

##### **2. On Non-metals**

- (i) To increase strength.
- (ii) To preserve and decorate the surfaces of non-metals like plastics, wood, glass, etc.
- (iii) For making the surface conductivity by utilization of light weight, non-metallic materials.

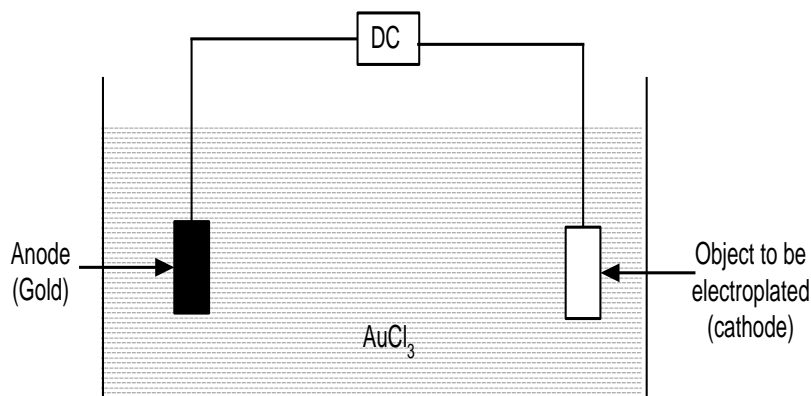
#### **Theory**

If the anode is made of coating metal itself in the electrolytic cell, during electrolysis, the concentration of electrolytic bath remains unaltered, since the metal ions deposited from the bath on cathode are replenished continuously by the reaction of free anions with the anode.

#### **Process**

The copper object, to be plated, is first treated with dil.  $\text{H}_2\text{SO}_4$ . The cleaned object is then made cathode of an electrolytic cell and gold foil as the anode.  $\text{AuCl}_3$  solution is taken as the electrolyte. When the current is passed from the battery through the solution, gold dissolves in the electrolyte and deposits uniformly on the copper object.

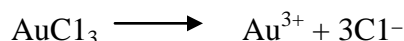




**Fig. 2.18 Electroplating of Gold**

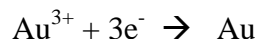
### Various chemical reactions

$\text{AuCl}_3$  ionizes as



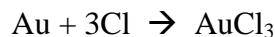
#### At Cathode:

On passing current,  $\text{Au}^{3+}$  ions move to the cathode and get deposited there as Au metal.



#### At anode:

The free chloride ions migrate to the gold anode and dissolve an equivalent amount of Au to form  $\text{AuCl}_3$ .



In order to get strong, adherent and smooth deposit certain additives (glue, gelatin, etc.,) are added to the electrolytic bath. To improve the brightness of deposit, brightening agents are added in the electrolytic bath. The favorable conditions for a good electrodeposits are optimum temperature ( $60^\circ\text{C}$ ), optimum current density ( $1-10 \text{ mA/cm}^2$ ) and low metal ion concentrations.

### Characteristics of Gold Plating

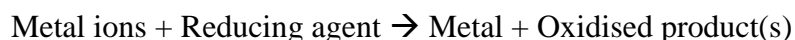
- (i) The deposits of gold are used for electrical and electronic applications.
- (ii) It is used for high quality decorations and high oxidation resistant coatings.
- (iii) For jewellery very thin coating is given ( $0.05 - 1.0 \text{ microns}$ ).

## 2.12.2 ELECTROLESS PLATING

### PRINCIPLE

Electroless plating is a technique of depositing a noble metal (from its salt solution) on a catalytically active surface of the metal to be protected, by using a suitable reducing agent without using electrical energy.

The reducing agent reduces the metallic ions to metal, which gets plated over the catalytically activated surface giving a uniform thin coating.



### EXAMPLE: ELECTROLESS NICKEL PLATING

#### Step I: Pretreatment and activation of the surface

The surface to be plated is first degreased by using organic solvents or alkali, followed by acid treatment.

#### Examples

- (i) The surface of the stainless steel is activated by dipping in hot solution of 50% dil.  $\text{H}_2\text{SO}_4$ .
- (ii) The surface of Mg alloy is activated by thin coating of Zn and Cu over it.
- (iii) Metals and alloys like Al, Cu, Fe, brass, etc., can be directly Ni - plated without activation.
- (iv) Non-metallic articles (like plastics, glass, etc.,) are activated by dipping them in the solution containing  $\text{SnCl}_2 + \text{HCl}$ , followed by dipping in palladium chloride solution. On drying a thin layer of Pd is formed on the surface.

#### Step II: Plating bath

| Nature of the compound         | Name of compound     | Quantity (g/l) | Function             |
|--------------------------------|----------------------|----------------|----------------------|
| Coating solution               | $\text{NiCl}_2$      | 20             | Coating metal        |
| Reducing agent                 | Sodium hypophosphite | 20             | Metal ions reduced   |
| Complexing agent cum exhaltant | Sodium succinate     | 15             | Improves the quality |
| Buffer                         | Sodium acetate       | 10             | Control the pH       |

|                     |       |   |   |
|---------------------|-------|---|---|
|                     |       |   |   |
| Optimum PH          | 4.5   | - | - |
| Optimum temperature | 93° C | - | - |

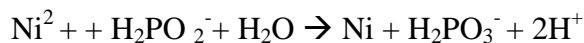
### Step III: Procedure

The pretreated object is immersed in the plating bath for the required time. During which the following reduction reaction will occur and the Ni gets coated over the object.

#### Various reactions



**Net reaction:**



#### Applications :

1. Electroless Ni-plating is extensively used in electronic appliances.
2. Electroless Ni-plating is used in domestic as well as automotive fields (eg., jewellery, tops of perfume bottles.)
3. Electroless Ni-coated polymers are used in decorative and functional works.
4. Electroless Cu & Ni coated plastic cabinets are used in digital as well as electronic instruments.

### 2.12.3 ADVANTAGES OF ELECTROLESS PLATING OVER ELECTROPLATING

1. No electricity is required.
2. Electroless plating on insulators (like plastics, glass) and semiconductors can be easily carried out.
3. Complicated parts can also be plated uniformly.
4. Electroless coatings possess good mechanical, chemical and magnetic properties.

**TABLE 2.1 DIFFERENCES BETWEEN ELECTROPLATING AND ELECTROLESS PLATING**

| S.No. | Electroplating  | Electroless plating   |
|-------|---|---|
| 1.    | It is carried out by passing current                          | It is carried out by auto catalytic redox reaction                    |
| 2.    | Separate anode is employed.                                   | Catalytic surface of the substrate acts as an anode.                  |
| 3.    | Anodic reaction is<br>$M \rightarrow M^{n+} + ne^{-}$         | Anodic reaction is<br>$R \rightarrow O + ne^{-}$                      |
| 4.    | Object to be coated is cathode.                               | Object to be coated, after making its surface catalytically active.   |
| 5.    | Cathodic reaction is<br>$M^{n+} + ne^{-} \rightarrow M$       | Cathodic reaction is<br>$M^{n+} + ne^{-} \rightarrow M$               |
| 6.    | It is not satisfactory for the object having irregular shape. | It is satisfactory for all parts.                                     |
| 7.    | It is carried out on conducting materials.                    | It is carried out on conducting, semi conducting (plastics) material. |
| 8.    | Thickness of the plating is<br>1-100 $\mu\text{m}$ .          | Thickness of the plating is 1-100 $\mu\text{m}$ .                     |