

# **TOTAL QUALITY MANAGEMENT**

## **UNIT- I**

### **Definition:**

- Total – Whole, entire, complete
- Quality – Excellence, class, meeting expectation
- Management – organising, administering, art of getting things done.

TQM is defined as both philosophy and a set of guiding principles that represent the foundation of continuously improving organisation. It is the application of quantitative methods and human resources to improve all the process within the organisation and exceed customer needs now and in the future.

Total Quality Management is an effective system for integrating the quality development, quality maintenance and quality improvement efforts of various groups in an organization continuously, so as to enable marketing, engineering, production and service at the most economic levels which allow for full customer satisfaction.

### **Historical Review of TQM**

Industrialization led to mass production in which it led to the concept of one product at a time to the assembly line of production. Though workmanship was affected but mass production led to more job and reduction in cost of the product and increase in quality, reduction of defects etc.

1924 – After WWI, W.A. Sherwat of Bell Telephone statistical chart for the control of various. Concept of sample tests were followed. It was a failure in the initial stages.

1946 – ASQC American Society for Quality Control, now ASQ. Frequent meetings, conferences and publications were made to public.

1950 – W.Edwards Demings his guidance and lecture to Japan engineers transformed quality concepts in the organisation. His cycle PLAN-DO-CHECK - ACT

1954 – Joseph M.Juran Concept of efficient and productive. Juran Trilogy  
Quality planning – Quality Control – Quality Improvement

1960 – Quality control circles was formed. Zero defects concepts

1970 – Reactive approach to proactive approach. Shift from Japan to USA

1980 – SPC – Statistical Process Control. Concepts of parameter and tolerance. Experiments 1990 – Concepts of certification of ISO, CMM etc

2000 – six sigma concept - **Six Sigma** stands for Six Standard Deviations (Sigma is the Greek letter used to represent standard deviation in statistics) from mean. **Six Sigma** methodology provides the techniques and tools to improve the capability and reduce the defects in any process.

### **TQM Basic Concepts**

- 1. Management Involvement** – Participate in quality program, develop quality council, direct participation
- 2. Focus on customer** – who is the customer – internal and external, voice of the customer, do it right first time and every time.
- 3. Involvement and utilisation of entire work force** – All levels of management
- 4. Continuous improvement** – Quality never stops, placing orders, bill errors, delivery, minimise wastage and scrap etc.
- 5. Treating suppliers as partners** – no business exists without suppliers.
- 6. Performance measures** – creating accountability in all levels

### **Barriers in TQM Implementation**

1. Lack of commitment from top management – avoiding training for self and employees, meetings
2. Lack of employee involvement – particularly at managerial level, supportive attitude, trust
3. Lack of team work – Co-operation and co-ordination within workers.
4. Lack of customer oriented approach – Know the customer need, demand, taste, shortcomings
5. Lack of attention to feedback and complaints –
6. Supplier control – in terms of materials, cost, quality, delivery etc
7. Review quality procedures – up gradation, correct past errors. Learn from experience

### **Five Pillars of TQM** are,

- Product
- Process
- System
- People
- Leadership

### **Benefits of TQM :**

#### **Customer satisfaction oriented benefits :**

1. Improvement in product quality
2. Improvement in product design
3. Improvement in production flow
4. Improvement in employee morale and quality consciousness
5. Improvement in product service
6. Improvement in market place acceptance

#### **Economic improvement oriented benefits :**

1. Reduction in operating costs
2. Reduction in operating losses
3. Reduction in field service costs
4. Reduction in liability exposure

#### **Principles of TQM :**

- ❖ Visionary leadership
- ❖ Customer-driven excellence
- ❖ Organizational and personal learning
- ❖ Valuing employees and partners
- ❖ Agility
- ❖ Focus on the future
- ❖ Managing for innovation
- ❖ Management by fact
- ❖ Public responsibility
- ❖ Focus of results and creating values
- ❖ Systems perspective

**Quality** – When a product or service meets or exceeds expectation considering the intended use and the selling price.

#### **Quality = performance / expectation**

Definition by ISO 9000:2000 It is defined as the degree to which a set of inherent characteristics fulfills requirement.

Degree – good, excellent, bad Inherent – existing, within, natural

Requirement – need or expectation

### **Dimensions of quality**

1. Performance - Fulfilment of primary requirement
2. Features - Additional things that enhance performance
3. Conformance - Meeting specific standards set by the industry
4. Reliability - Consistence performance over a period of time
5. Durability - Long life and less maintenance
6. Service - Ease of repair, guarantee, and warranty
7. Response - Dealer customer relationship, human interface
8. Aesthetics - exteriors, packages
9. Reputation - Past performance, ranking, branding

### **Quality Policy:**

The Quality Policy is a guide for everyone in the organization as to how they should provide products and service to the customers. The common characteristics are :

- ❖ Quality is first among equals.
- ❖ Meet the needs of the internal and external customers.
- ❖ Equal or exceed the competition.
- ❖ Continually improve the quality.
- ❖ Include business and production practices. Utilize the entire work force

### **Quality Cost Analysis**

The main language of corporate management is money, so the concept of studying quality-related costs is essential. The quality guru, Joseph Juran has been advocating the analysis of quality-related costs since 1951. He give his theory of quality improvement which is commonly known as Juran Trilogy.

**Quality costs:** The costs that are associated with preventing, finding, and correcting defective work are Quality Costs. Normally, these costs are running at 20% – 30% of sales.

Many of these costs can be significantly reduced or completely avoided. One of the key functions of a Quality Analysis / Engineer is the reduction of the total cost of quality associated with a product / service.

### **Below are the main Quality Costs:**

- ❖ Prevention Costs
- ❖ Appraisal Costs
- ❖ Failure Costs
- ❖ Internal Failure Costs
- ❖ External Failure Costs

Total Cost of Quality can be calculated as the sum of costs:

Prevention + Appraisal + Internal Failure + External Failure

**Prevention Costs:** Costs of activities that are specifically designed to prevent poor quality which include

- ❖ Coding errors
- ❖ Design errors
- ❖ Mistakes in the user manuals
- ❖ Deadly documented or unmaintainably complex code

Most of the prevention costs don't fit within the Testing Group's budget. This money is spent by the programming, design, and marketing staffs.

**Appraisal Costs:** Costs of activities designed to find quality problems, such as code inspections and any type of testing.

Design reviews are part of prevention and part appraisal. Please note the following two points:

1. To the degree that you're looking for errors in the proposed design itself when you do the review, you're doing an appraisal.
2. To the degree that you are looking for ways to strengthen the design, you are doing prevention.

**Failure Costs:** Costs that result from poor quality, such as the cost of fixing bugs and the cost of dealing with customer complaints.

**Internal Failure Costs:** Failure costs that arise before your company supplies its product to the customer. Along with costs of finding and fixing bugs are many internal failure costs borne by groups outside of Product Development. If a bug blocks someone in your company from doing his or her job, the costs of

- the wasted time
- the missed milestones
- and the overtime to get back onto schedule

are all internal failure costs.

The UI issues / bugs / defects – the ones that will be fixed later – can make it hard for these staff members to take accurate screen shots. Delays caused by these minor design flaws, or by bugs that block a packaging staff member from creating or printing special reports, can cause the company to miss its printer deadline.

**External Failure Costs:** External failure costs are much higher. The costs that arise after your company supplies the product to the customer such as

- Customer service costs
- Cost of patching a released product distributing the patch

It is much cheaper to fix problems before shipping the defective product to customers.

**Examples of Prevention Costs:**

- Fault-tolerant design
- Defensive programming
- Usability analysis
- Clear specification
- Staff training
- Requirements analysis
- Early prototyping
- Accurate internal documentation
- Evaluation of the reliability of development tools

**Examples of Appraisal Costs:**

- Training testers
- Beta testing
- Test automation
- Usability testing
- Design review
- Code inspection
- Glass box testing
- Black box testing

**Examples of Internal Failure Costs:**

- Training testers
- Beta testing
- Test automation
- Usability testing
- Design review
- Code inspection
- Glass box testing
- Black box testing

**Examples of External Failure:**

- Lost sales
- Lost customer goodwill
- Discounts to resellers to encourage them to keep selling the product
- Warranty costs
- Liability costs
- Penalties
- Technical support calls
- Preparation of support answer books

- Investigation of customer complaints
- Refunds and recalls
- Coding / testing of interim bug fix releases
- Shipping of updated product
- All other costs imposed by law

### **Customer perception of quality**

Before 1988 – Performance, Prize and service After 1989 – Performance, service and prize ASQ – American Society for Quality

1. Performance – availability (ready for use), reliability (free from failure), maintainability
2. Features – psychological and technical. Added feature along with main usage
3. Service – intangible, made up of many small things
4. Warranty – Vs guarantee. Customer feels comfortable with this
5. Price – value for money, ready to pay at the same time comparative study to be done
6. Reputation – Branding merges with quality. Good exp reaches 6 bad reaches 15

### **Service Quality**

Shift in focus from manufacturing industry to service industry and the services involved in manufacturing organization.

Customer service is the set of activities an organization uses to win, attract and retain customers. It can be provided before, during and after the sale of the product.

### **Elements of customer service**

#### *Organization*

1. Identify each segment – where the organization needs to concentrate on quality
2. Write down requirement – Proper documentation of quality policy in the form of a handbook
3. Communicate requirements – Inform its importance to all levels in the organisation
4. Organize process – create a systematic process as it is ongoing and never ending process
5. Organize physical spaces – aesthetics, atmosphere, room space, recreation, wifi etc

**Customer Care – Henry Ford – The boss just handles the cash it is the customer who pays your salary**

1. Meet the customers expectation – treat all customers alike, respond quickly
2. Get the customer's point of view – think in the point of view of a customer
3. Deliver what is promised – keep up promise at any cost
4. Make the customer feel valued – customer must feel that due respect and importance is given to him
5. Respond to all complaints – minimize complaints and eradicate similar and repeated complaints.
6. Over-respond to customer – make him feel he is cloud nine
7. Provide clean and comfortable reception area – cleanliness, spacious, dress code, weather etc

**Communication – All forms of communication written, verbal, advt, web site must prove quality**

1. Optimize trade off between time and personal attention
2. Minimize the number of contact points – channels and levels
3. Provide pleasant and knowledgeable enthusiastic employees
4. Write document in customer friendly language – simple and point blank

**Front-line people – The people who have first and direct contact or interaction with the customer**

1. Hire people who like people – train groom them
2. Challenge them to develop better methods – small changes in packing, billing etc
3. Give them authority to solve problems – give discounts, free gifts etc
4. Serve them as internal customers
5. Make sure they are adequately trained – written and oral communication, body language etc
6. Recognize and reward performance - Nordstorm example obsess with the customer

**Customer Retention**

- It is the final result of customer satisfaction and customer loyalty
- Most cases what customer says or feels may vary from actual consumption or purchase
- Customer must refer more customers and increase the revenue
- External research must be done to feel the pulse of the customer
- Employee retention is proportional customer retention



### Quality cost:

During the 1950's the concept of -Quality Cost emerged. Different people assigned different meanings to the term. Some people equated quality cost with the cost of attaining quality; some people equated the term with the extra incurred due to poor quality. But, the widely accepted thing is -Quality cost is the extra cost incurred due to poor or bad quality of the product or service.

### Categories of Quality Cost :

Many companies summarize quality costs into four broad categories. They are,

- a) Internal failure costs - The cost associated with defects that are found prior to transfer of the product to the customer.
- b) External failure costs - The cost associated with defects that are found after product is shipped to the customer.
- c) Appraisal costs - The cost incurred in determining the degree of conformance to quality requirement.
- d) Prevention costs - The cost incurred in keeping failure and appraisal costs to a minimum.

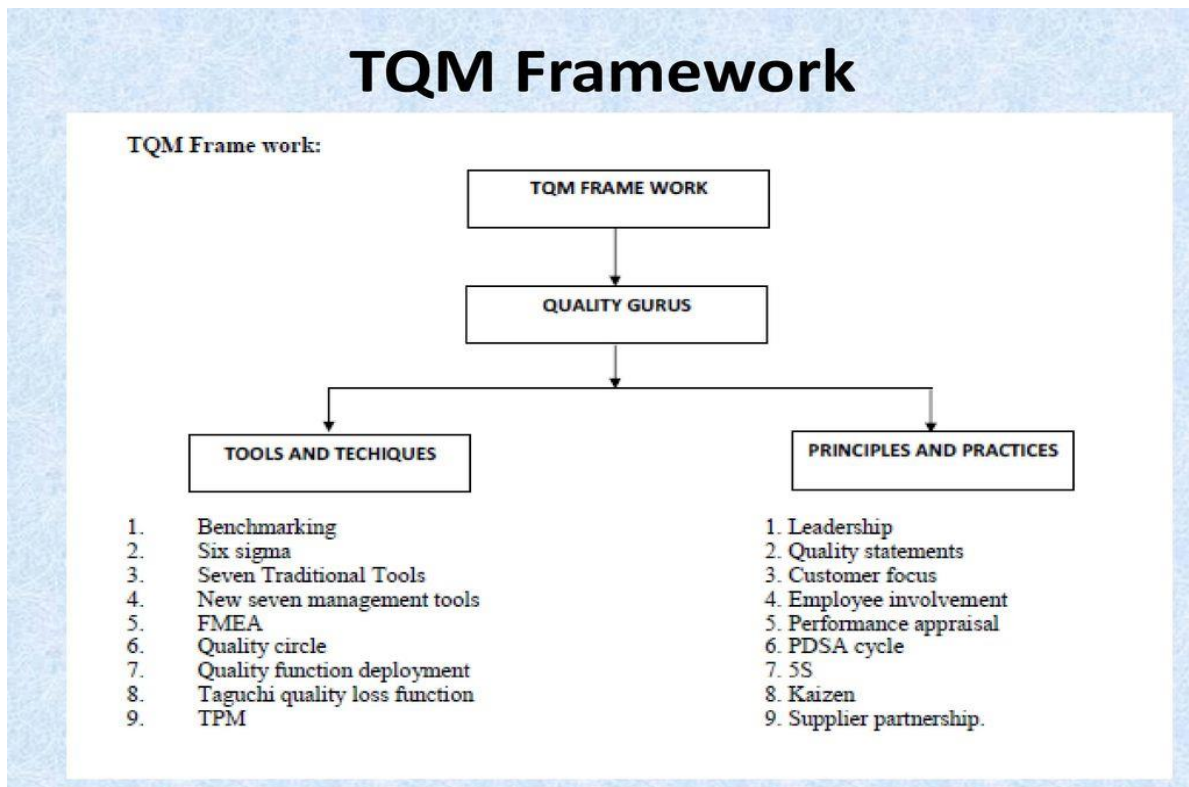

## **5-S PRINCIPLES**

The 5S framework was originally developed by just-in-time expert and international consultant Hiroyuki Hirano. The 5S framework is an extension of Hirano's earlier works on just-in-time production systems. The 5Ss represent a simple "good housekeeping" approach to improving the work environment consistent with the tenets of Lean Manufacturing System.

It promotes daily activity for continuous improvement. It fosters efficiency and productivity while improving work flow. It encourages a proactive approach that prevents problems and waste before they occur. It provides a practical method for dealing with the real problems that workers face every day. And it fits with a facility's other efforts, such as total preventive maintenance, just-in-time manufacturing, pollution prevention, safety initiatives, and lean manufacturing efforts.

### **SEIRI / SORT / CLEANUP:**

The first step of the "5S" process, Seiri, refers to the act of throwing away all unwanted, unnecessary, and unrelated materials in the workplace. People involved in Seiri must not feel sorry about having to throw away things. The idea is to ensure that everything left in the workplace is related to work. Even the number of necessary items in the workplace must be kept to its absolute minimum.

There are two main objectives of Seiri; first is the simplification of tasks and effective use of space. In performing Seiri, this simple guideline is a must:

1. Separate needed items from unneeded items.
2. Remove unneeded items from working areas.
3. Discard the items never used.
4. Store items not Item not needed now.
5. Remove all excess items from working areas, including work pieces, supplies, personal items, tools, instruments, and equipment.
6. Use red tag to get rid of unneeded items.
7. Store items needed by most people in a common storage area.
8. Store items only needed by each individual in his/her own working area.
9. Organize working / storage area.

### **SEITON / SET IN ORDER / ARRANGING:**

Seiton, or orderliness, is all about efficiency. This step consists of putting everything in an assigned place so that it can be accessed or retrieved quickly, as well as returned in that same place quickly. If everyone has quick access to an item or materials, work flow becomes efficient, and the worker becomes productive. Every single item must be allocated its own

place for safekeeping, and each location must be labeled for easy identification of what it's for.

Its objective includes; the needed items can be easily found, stored and retrieved, supports efficiency and productivity, First-in first-out (FIFO), and save space and time.

In performing Seiton, follow these guidelines:

1. A place for everything and everything in its place.
2. Place tools and instructional manual close to the point of use.
3. Store similar items together. Different items in separate rows.
4. Don't stack items together. Use rack or shelf if possible.
5. Use small bins to organize small items.
6. Use color for quickly identifying items.
7. Clearly label each item and its storage areas (lead to visibility).
8. Use see-through cover or door for visibility.
9. Use special designed cart to organize tools, jigs, measuring devices, etc., that are needed for each particular machine.

### **SEISO / SHINE / NEATNESS**

Seiso, the third step in "5S", says that 'everyone is a janitor.' Seiso consists of cleaning up the workplace and giving it a 'shine'. Cleaning must be done by everyone in the organization, from operators to managers. It would be a good idea to have every area of the workplace assigned to a person or group of persons for cleaning. Seiso is not just cleaning, but a whole attitude that includes ensuring everything is in perfect condition. Everyone should see the 'workplace' through the eyes of a visitor - always thinking if it is clean enough to make a good impression.

Its objective includes; cleanliness ensures a more comfortable and safe working place, cleanliness will lead to visibility so as to reduce search time and cleanliness ensures a higher quality of work and products.

Follow these guidelines in performing Seiso:

1. Use dust collecting covers or devices to prevent possible dirt or reduce the amount of dirt.
2. Investigating the causes of dirtiness and implement a plan to eliminate the sources of dirt.
3. Cover around cords, legs of machines and tables such that dirt can be easily and quickly removed.
4. Operators clean their own equipment and working area and perform basic preventive maintenance.
5. Keep everything clean for a constant state of readiness.

## **SEIKETSU / SYSTEMIZE / DISCIPLINE:**

The fourth step of "5S", or seiketsu, more or less translates to 'standardized clean-up'. It consists of defining the standards by which personnel must measure and maintain 'cleanliness'. Seiketsu encompasses both personal and environmental cleanliness. Personnel must therefore practice 'seiketsu' starting with their personal tidiness. Visual management is an important ingredient of seiketsu. Color-coding and standardized coloration of surroundings are used for easier visual identification of anomalies in the surroundings. Personnel are trained to detect abnormalities using their five senses and to correct such abnormalities immediately.

The guidelines include:

1. Removing used, broken, or surplus items from the work area
2. Making safety a prime requirement by paying attention to noise, fumes, lighting, cables, spills, and other aspects of the workplace environment
3. Checking that items are where they should be
4. Listening to the "voice" of the process and being alert to things such as unusual noises
5. Ensuring that there is a place for everything and that everything is in its place
6. Wearing safe working apparel and using safe equipment
7. Minimizing all waste and the use of valuable resources such as oil, air, steam, water, and electricity

## **SHITSUKE / SUSTAIN / ON-GOING IMPROVEMENT:**

The last step of "5S", Shitsuke, means 'Discipline.' It denotes commitment to maintain orderliness and to practice the first 4 S as a way of life. The emphasis of shitsuke is elimination of bad habits and constant practice of good ones. Once true shitsuke is achieved, personnel voluntarily observe cleanliness and orderliness at all times, without having to be reminded by management.

The characteristic of 5S tends to overlap significantly rather than cover very different subjects. Rather than worry about what fits into Seiri and what fits into Seiton, use them to reinforce each other and implement the whole thing.

## **QUALITY CIRCLE**

Quality Circle is a small group of 6 to 12 employees doing similar work who voluntarily meet together on a regular basis to identify improvements in their respective work areas using proven techniques for analysing and solving work related problems coming in the way of achieving and sustaining excellence leading to mutual upliftment of employees as well as the organisation. It is "a way of capturing the creative and innovative power that lies within the work force".

### **CONCEPT**

The concept of Quality Circle is primarily based upon recognition of the value of the worker as a human being, as someone who willingly activates on his job, his wisdom, intelligence, experience, attitude and feelings. It is based upon the human resource management considered as one of the key factors in the improvement of product quality & productivity. Quality Circle concept has three major attributes:

## **CONTRIBUTIONS OF DEMINGS**

Deming's work and writing constitute not so much a technique, as a philosophy of management, Total Quality Management, that focuses on quality and continuous improvement but which has had - justifiably - a much wider influence.

Here we will consider Deming's interest in variation and his approach to systematic problem solving which led on to his development of the 14 points which have gained widespread recognition and which are central to the quality movement and his philosophy of transformational management. Deming's seven deadly diseases of management and his use and promotion of the PDCA cycle, known to many as the Deming Wheel, are described below:

### **Variation and problem solving**

The key to Deming's ideas on quality lies in his recognition of the importance of variation. In Out of the crisis he states:

'The central problem in management and in leadership is failure to understand the information in variation'.

Deming was preoccupied with why things do not behave as predicted. All systems (be they the equipment, the process or the people) have variation, but he argued that it is essential for managers to be able to distinguish between special and common causes of variation. He developed a theory of variation - that special causes of variation are usually easily attributable to quickly recognisable factors such as changes of procedure, change of shift or operator etc, but that common causes will remain when special causes have been eliminated (normally due to design, process or system). These common causes are often recognised by workers, but only managers have the authority to change them to avoid repeated occurrence of the problem. Deming estimated that management was responsible for more than 85% of the causes of variation. This formed his central message to the Japanese.

### **Demings 14 Points Summarised**

1. Create constancy of purpose and continual improvement
2. Adopt the new (Japanese) philosophy – by management and workers alike.
3. Do not depend on (quality) inspection – build quality into the product and process
4. Choose quality suppliers
5. Improve constantly – to reduce variation in all aspects
6. Training on the job – for workers and management.
7. Leadership not supervision – to get people to do a better job, not just meet targets.
8. Eliminate fear – encourage two-way communication, encourage employees
9. Break down internal barriers – department's are –internal customers
10. Eliminate slogans (exhortations) – processes make mistakes not people.
11. Eliminate numerical targets – management by objectives not numbers
12. Remove barriers to worker satisfaction – including annual appraisals
13. Encourage self improvement and education for all
14. Everyone is responsible for continual improvement in quality and productivity – particularly top management

## **CONTRIBUTIONS OF JURAN TRILOGY**

The Trilogy consists of three sequential and logical groups of activities:

- Quality Planning
- Quality Control
- Quality Improvement All three processes are universal
- Applied to a particular process
- Performed by top management or by middle management

### **Juran Trilogy:**

A systematic and comprehensive system for break-through quality improvements  
Quality Defined: meet customer needs and freedom from deficiencies

### **Trilogy Components**

- ❖ Quality Planning – discover customer needs and deficiencies and design adequate processes
- ❖ Quality Control -- compare actual performance to goals and take action on the differences
- ❖ Quality Improvement -- the attainment of unprecedented levels of performance.

## **CONTRIBUTIONS OF CROSBY**

Crosby's approach to quality was unambiguous. In his view, good, bad, high, and low quality are meaningless concepts in the abstract; the meaning of quality is "conformance to requirements." What that means is that a product should conform to the requirements that the company has itself established based on its customers' needs. He also believed, that the prime responsibility for poor quality lies with management, not with the workers. Management sets the tone for the quality initiative from the top.

Nonconforming products are ones that management has failed to specify or control. The cost of nonconformance equals the cost of not doing it right first time, and not rooting out any defects in processes.

"Zero defects" does not mean that people never make mistakes, but that companies should not begin with "allowances" or substandard targets with mistakes as an inbuilt expectation. Instead, work should be seen as a series of activities or processes, defined by clear requirements and carried out to produce identified outcomes. Systems that allow things to go wrong and that result in those things having to be done again can cost organizations between 20% and 35% of their revenues, in Crosby's estimation. His seminal approach to quality was set out in Quality is Free.

1. **Management commitment it:** the need for quality improvement must be recognized and accepted by management, who then draw up a quality improvement program with an emphasis on the need for defect prevention. Quality improvement equates to profit improvement. A quality policy is needed which states that "...each individual is expected to perform exactly like the requirement or cause the requirement to be officially changed to what we and the customer really need."
2. **The quality improvement team:** representatives from each department or function should be brought together to form a quality improvement team. Its members should be people who have sufficient authority to commit the area they represent to action.
3. **Quality measurement:** the status of quality should be determined throughout the company. This means establishing and recording quality measures for each area of activity in order to show where improvement is possible and where corrective action is necessary. Crosby advocated delegation of this task to the people who actually do the job, thus setting the stage for defect prevention on the job, where it really counts.
4. **The cost of quality evaluation:** the cost of quality is not an absolute performance measurement, but an indication of where the action necessary to correct a defect will result in greater profitability.
5. **Quality awareness:** this involves making employees aware of the cost to the company of defects, through training and information, and the provision of visible evidence of the results of a concern for quality improvement. Crosby stresses that this sharing process is a key, or even the key, step in the progress of an organization toward quality.
6. **Corrective action:** discussion of problems will result in the finding of solutions and also bring to light other elements that are in need of improvement. People need to see that problems are regularly being resolved. Corrective action should then become a habit.
7. **Establishing an ad hoc committee for the zero defects program:** zero defects is not a motivation program: its purpose is to communicate and instill the notion that everyone should do things right first time.
8. **Supervisor training:** all managers should undergo formal training on the Fourteen Steps before they are implemented. Managers should understand each of the Fourteen Steps well enough to be able to explain them to their people.
9. **Zero defects day:** it is important that the commitment to zero defects as the performance standard of the company makes an impact, and that everyone gets the same message in the same way. Zero defects day, when supervisors explain the program to their people, should make a lasting impression as a



"new attitude" day.

10. **Goal setting:** all supervisors ask their people to establish specific, measurable goals that they can strive for. Usually, these comprise 30-, 60-, and 90-day goals.
11. **Error cause removal:** employees are asked to describe, on a simple, one-page form, any problems that prevent them from carrying out error-free work. Problems should be acknowledged and begin to be addressed within 24 hours by the function or unit to which they begin to grow more confident that their problems will be attended to and dealt with.
12. **Recognition:** it is important to recognize those who meet their goals or perform outstanding acts with a prize or award, although this should not be in financial form. The act of recognition itself is what is important.
13. **Quality councils:** the quality professionals and team leaders should meet regularly to discuss improvements and upgrades to the quality program.
14. **Doing it over again:** during the course of a typical program lasting from 12 to 18 months, turnover and change will dissipate much of the educational process. It is important to set up a new team of representatives and begin the program again from the beginning, starting with zero defects day. This "starting over again" helps quality to become ingrained in the organization

### **TAGUCHI'S CONTRIBUTION**

Genichi Taguchi is a Japanese quality expert, known for the Quality Loss Function and for methodologies to optimise quality at the design stage – *-robust design*. Taguchi received formal recognition for his work including Deming Prizes and Awards.

Genichi Taguchi considers quality loss **all the way through to the customer**, including cost of scrap, rework, downtime, warranty claims and ultimately reduced market share.

#### **Genichi Taguchi's Quality Loss Function**

The Quality Loss Function gives a financial value for customers' increasing dissatisfaction as the product performance goes below the desired target performance. Equally, it gives a financial value for **increasing costs** as product performance goes above the desired target performance. Determining the target performance is an educated guess, often based on customer surveys and feedback.

The quality loss function allows **financial decisions** to be made at the **design stage** regarding the cost of achieving the target performance.

## **CONTRIBUTIONS OF MASAOKI IMAI**

Masaaki Imai is Founder of KAIZEN Institute (KI), which was established in Switzerland (1985) to help companies introduce KAIZEN® concepts, systems, and tools. KI (also now known as KAIZEN Institute Consulting Group- KICG) has offices in over 30 countries around the globe. Over the last 30+ years, Mr. Imai has held lectures on KAIZEN, Lean and other related management subjects, as well as having consulted with global companies (outside of Japan) and assisting them in their process of introducing change and continual improvement. KAIZEN Institute dispatches both local and global consultants, who are corporate managers and academics and considered experts in the various technicalities of KAIZEN, to various assignments to work closely with the local KAIZEN consultants. Mr. Imai's role has been one of integrating various KAIZEN management practices, such as Just-in-time, TQM, and TPM, into the cultural environment of client companies. KAIZEN Institute regularly sponsors KAIZEN Tours, within Japan, Europe and other strategic locations where best practices can be found. .

**Kaizen** is defined as making -continuous improvement|| - slow, incremental but constant. Western way of pragmatic approach -why-fix-it-if-it-ain't-broke|| Kaizen extends a more optimistic philosophical view: -Everything—even if it ain't broke—can be made better!! "kai- > Means "change" or "the action to correct" "zen- > means "good- Importance is given to the process not the results, as Japanese believe that good process will deliver good results.

- i. Quality Circle is a form of participation management.
- ii. Quality Circle is a human resource development technique.
- iii. Quality Circle is a problem solving technique.

## **UNIT – II**

### **STEPS IN IMPLEMENTING TQM**

**Total Quality Management stands on 7 key pillars.**

#### **1. Focus on the Customer**

Customers are the true North Star and barometer of a business. In the TQM approach, customer sentiments and feedback are closely monitored through call tracking and surveys.

#### **2. Employee Involvement**

Employees must understand why the obsession with improvement ultimately gives them the freedom to innovate on their jobs. TQM not only boosts the financial health of a business, it also improves talent connectedness and communication.

#### **3. Process Centeredness**

The requirements are met by defining processes. There should be processes to collect and integrate customer and employee feedback. There should be distinct processes to course correct on the TQM journey by adjusting strategy and tactics. And even a set of processes to measure the process centeredness of the implementation.

#### **4. Integrated Structure**

Silos stymie Total Quality Management. As discussed, though the concept advocates structure and processes, isolation is not favoured. Different departments in the organization need to learn from each other and refine their processes in collaboration.

#### **5. Strategic Approach**

Begin with the company vision and objectives to achieve. Set the processes according to this overarching strategy. Then let the TQM changes manifest as changes in culture, vision and objectives.

#### **6. Clear Communication**

Without clear, unhesitant communication between employees and between a business and its customers, gathering authentic feedback and

driving improvements is impossible. In any power dynamic, the final say should be in favour of the approach dictated by data and honest feedback.

## **7. Iterative Improvement**

TQM is capable of ushering changes because when an organizational sensor actually “senses” a gap, action is taken according to defined processes and improvements are made to eliminate the errors. The best feedback loop is useless if continuous improvement isn’t prioritized.

### **Advantages of TQM:**

#### **(i) Sharpens Competitive Edge of the Enterprise:**

TQM helps an organisation to reduce costs through elimination of waste, rework etc. It increases profitability and competitiveness of the enterprise; and helps to sharpen the organisation’s competitive edge, in the globalized economy of today.

#### **(ii) Excellent Customer Satisfaction:**

By focusing on customer requirements, TQM makes for excellent customer satisfaction. This leads to more and more sales, and excellent relations with customers.

#### **(iii) Improvement in Organisational Performance:**

Through promoting quality culture in the organisation, TQM lead to improvements in managerial and operative personnel’s performance.

#### **(iv) Good Public Image of the Enterprise:**

TQM helps to build an image of the enterprise in the minds of people in society. This is due to stress on total quality system and customers’ requirements, under the philosophy of TQM.

#### **(v) Better Personnel Relations:**

TQM aims at promoting mutual trust and openness among employees, at all levels in the organisation. This leads to better personnel relations in the enterprise.

1) Emphasizing the needs of the market:

QM helps in highlighting the needs of the market. Its application is universal and helps the organization to identify and meet the needs the market in a better way.

2) Assures better quality performance in every sphere of activity:

Adverse and non-participative attitudes of the employees are the biggest obstacles in the organization success, growth and advancement.

TQM stresses on bringing attitudinal changes and improvements in the performance of employees by promoting proper work culture and effective team work

3) Helps in checking non-productive activities and waste:

Every organization aims at improving productivity as well as reduction in cost so as to result in increase in profitability.

Under TQM, quality improvement teams are constituted to reduce waste and inefficiency of every kind by introducing systematic approach.

4) Helpful in meeting the competition:

TQM techniques are greatly helpful in understanding the competition and also developing an effective combating strategy. Due to the cut throat competition, the very survival of many organizations has become very vital issue.

5) It helps in developing an adequate system of communication:

Faulty and inadequate communication and improper procedures act as stumbling blocks in the way of proper development of an organization.

It results in misunderstanding, low- productivity, poor quality, duplication of efforts and low morale. QM techniques bind together members of various related sections, departments and levels of management for effective communication and interaction.

## **Limitations of TQM:**

### **1) Production Disruption**

Implementing a Total Quality Management system in a company requires extensive training of employees and these requires them to take some time of their day to day work duties.

While the improvements do reduce lead time, eliminate waste and improve productivity, the beginning stages of implementing Total Quality Management in an organization can reduce worker output.

### **2) Employee Resistance**

Total Quality Management requires change in mindset, attitude and methods for performing their jobs. When management does not effectively communicate the team approach of Total Quality Management, workers may become fearful, which leads to employee resistance. When workers resist the program, it can lower employee morale and productivity for the business.

### **3) Quality is Expensive**

TQM is expensive to implement. Implementation often comes with additional training costs, team-development costs, infrastructural improvement costs, consultant fees and the like.

### **4) Discourages Creativity**

TQM focus on task standardization to ensure consistency discourages creativity and innovation. It also discourages new ideas that can possibly improve productivity

## **Barriers to TQM.**

There are a number of common potential setbacks in the introduction and implementation of a total quality management system. These can arise due to the commitment of senior management, the existing culture within an organization, the number and focus of teams, the ability and desire to truly engage all employees, the focus of the TQM effort and commitment to continuous education and training.

### 1. **Senior Management commitment.**

The biggest single reason for a total quality program to fail to deliver significant benefits to an organization is poor leadership by senior management. Senior management must lead by example and systematically seek to implement and continually improve all the required elements of TQM. Senior management cannot stand back and delegate the TQM effort, they must enthusiastically demonstrate an understanding, appreciation and buy-in for total quality in their daily actions. Where problems arise on a daily basis, senior management must insist on fact based analysis. They must consistently recognise positive team performance. They must encourage all employees to participate and contribute to organizational performance improvement. Failure by senior management to live TQM on a daily basis, will send a clear message to employees that total quality is not truly valued within the organization.



665

## **TQM Tools and Techniques. Information and Training presentation.**

### 2. **Culture.**

The existing culture within an organization is critical to the effective implementation of a positive, effective, total quality approach to improvement. A culture of mistrust, them versus us, change resistance, etc., will stall and ultimately stop the implementation of TQM. The culture within an organization must be supportive of positive change and encourage open two-way communications. TQM may force management to plan efforts towards culture change.

### **3. Team Mania.**

Teamwork is a critical part of TQM, however putting people in teams before the TQM culture has been developed can result in poor results. Too many teams can also be a real problem. Team attendance needs to be carefully monitored, as often the same people end up on a range of teams, will little time left in their working day to truly contribute to the team, while in parallel, many other employees, never sit on a team nor or asked to contribute. The objective must be to harness the capabilities of all employees. Therefore, as many employees as possible must in some way contribute to improvement activities. This may be via partaking on teams. However, all teams must be carefully considered, with clear objectives, properly considered membership, clear end goals and appropriate recognition for positive efforts where positive results are delivered.

### **4. Deployment Process.**

It is important to get all key groups on board (e.g. all managers, employees, suppliers) before rolling out TQM projects. No single group of stakeholders can deliver total quality performance, nor can TQM be achieved while missing a key stakeholder group.

### **5. Taking too narrow or too broad an approach.**

Unless the quality program is tailored to fit the organization, problems will arise during implementation. Careful consideration needs to be given to the scope of the TQM program, where does the organization see the status of TQM in say one, two, five years time? TQM is a long term project. It is entirely reasonable to commence TQM via small steps. Maybe the first starting point will be to develop the use of analytical tools such as **cause and effect, fault tree analysis, hazop analysis**, etc.. Then when these start to get applied, the next step may be to introduce employee recognition, then improvement teams, etc.. The plan for TQM should be developed with all employees and shared with all employees, along with the planned milestone targets.

### **6. Training & Education.**

A critical component in any TQM program. What will be the approach to staff development? This also sits with plans to improve delegation and decision making. Developing more capable staff, can also motivate the staff, however, as staff competence is developed, so too must the opportunities available to utilize new skills be made available to those same staff, otherwise the outcome of training can actually be lower levels of motivation. Again, there should be a clear plan for education and training which in integral with the overall TQM program.



### **The barriers to TQM implementation and Deming Philosophy**

- Lack of management commitment
- Inability to change organizational culture
- Improper planning
- Lack of continuous training and education
- Incompatible organizational structure and isolated individuals and departments
- Ineffective measurement techniques and lack of access to data and results.
- Paying inadequate attention to internal and external customers.
- Inadequate use of empowerment and teamwork

### **Total Quality Control (TQC)**

Total Quality Control is the organised Kaizen activities involving everyone in the company-managers and workers- in totally integrated effort toward improving performance at every level. This improved performance is directed toward satisfying such cross- functional goals- as quality, cost, scheduling, manpower, development, and new product development. It is assumed that these activities ultimately lead to increased customer satisfaction.

The term total quality control (TQC) originated in the United States in the mid-to late 1950's. It had its origins in mass production and Scientific Management concepts, also labeled Taylorism, and its roots in the Ford Motor Company with the introduction of the moving track. The main purpose of quality control was how to eliminate production defects in manufacturing. The 1980s saw a revolution in both, the management's philosophies and the technologies by which production is carried out. Concepts such as like Just-in-time (JIT) were introduced by the Japanese whose purpose was to increase production with minimum use of inventories and at the same time with lowest amounts of defects. However, the duality of JIT and TQC formed since then a major cornerstone in the production and service practices around the globe.

### **Difference between Classical and Total Quality Control**

Classical control represents the past trends of American management, where specialization and division of labor were emphasized. Instead of working together to solve any deviations from the plan, time was spent arguing over who is responsible for the deviation. This sectionalism, as the Japanese refer to it, hinders collective efforts to improve the way things are done and lowers national productivity and the standards of living. Whereas, the Total Quality

Control, is represented by the PDCA (plan-do-check-act) continuous improvement cycle. This cycle is used by the Japanese to describe the cycle of control. “There need be nothing threatening about control if it is perceived as exercised in order to gather the facts necessary to make plans and take action toward making improvements.”

### **Factors influencing Total Quality Control (TQC)**

**1. Markets.** The number of new products offered in the market place has grown continuously accompanied by ever changing new technologies and methods of manufacturing. Consumers are more sophisticated as a result of higher specialization in the goods and services offered. Moreover, markets have no borders and much broader in scope leading businesses to be highly flexible and able to change direction rapidly.

**2. Money.** The increase of competition led many organizations to invest more in automation technology. This fact increased quality costs and made managers to focus on the quality-cost area as one of the “soft spots” in which its operating costs and losses can be decreased to improve profits. The early efforts to increase in plant investment, financed through increased productivity, has made losses in production extremely serious.

**3. Management.** Responsibility for quality has become a cross-functional and distributed effort among several groups, from engineering to marketing, manufacturing, and service. For example, new operations management schemes involve many parties within and outside the organization.

**4. Labor.** The rapid growth in technical knowledge and the creation of new fields require workers with a high specialization. This situation has created the need for hybrid knowledge workers who can integrate the work of the different fields in order to reach the desired level of quality.

**5. Motivation.** The complexity of producing quality products has magnified the need for quality contribution from every employee. In addition to monetary reward, workers need to feel a sense of accomplishment in their jobs. This led management to intensify training in quality education and improve communication of quality consciousness.

**6. Materials.** Looking at production costs and quality requirements, the new materials used are intended for special applications. Chemical and physical measurements must be made using highly specialized laboratory machines in order to control quality.

**7. Machines, mechanization and automation.** The demand of companies to get cost reductions and production volume to satisfy consumer’s needs has forced the use of more complex manufacturing equipment. But mechanization

and automation make good quality critical because reducing cost may not raise worker and machine utilization to satisfactory values.

**8. Modern information systems.** The new and constantly improving methods of data processing provide the means for an unprecedented level of control of machines and manufacturing processes as well as control of products and services even after they have reached the customer. Management can obtain far more useful, accurate, timely and predictive information upon which to base the decisions concerning the business.

**9. Mounting product requirements.** Increased complexity and higher performance requirements for products intensified the importance of product safety and reliability. Management must give attention to make sure that no factors enter the process to decrease the reliability of components or systems

#### **Why total quality control concept is adopted**

1. Improving the corporate health and character of the company
2. Establishing a cooperative system by combining the efforts of all employees and achieving participation by all
3. Establishing the quality assurance system and obtaining the confidence of customers and consumers
4. Developing new products for the purpose of achieving the best possible quality in the world
5. Establishing a management system capable of securing profits in times of recession
6. Showing respect for humanity by considering employees welfare
7. Utilization of quality control statistical techniques.

#### **Benchmarks for successful application of Total Quality Control**

1. Quality is a company-wide process. Quality is customer-connected process that must be implemented throughout the overall operation of the company and not through the operation of a single department.
2. Quality is what the customer says it is. The customer or end user judges the quality of the product and not the engineer or the merchant.
3. Quality and cost are a sum not a difference. In order for quality to yield higher return on investment by making products better, management must identify quality cost.
4. Quality requires both individual and team work zealotry. Organizing the quality work of individuals as well as of the quality teamwork among departments is essential for the success of quality programs.
5. Quality is a way of managing. Good management enables the individual worker to implement his quality knowledge, skills and attitudes in the

organization knowing that making quality right makes everything else in the company right.

6. Quality and innovation are mutually dependent. The key to successful new product launched is to make quality the partner of product development from the beginning.

7. Quality is an ethic. Human emotional motivation must be built. It is the basic driver in true quality leadership. Quality programs which are based only on statistics always fail.

8. Quality requires continues improvement. Quality is a constantly upward moving target. Continuous improvement is an integral component of a quality program which requires help, participation, and involvement from all the company's personnel and suppliers.

9. Quality is the most cost-effective, leas capital-intensive route to productivity. Some of the strongest companies in the world have blindsided competition by eliminating the part of the company which exists because of bad work. They started implementing the quality productivity concept and backed it with the application of a wide range of new and existing quality technology.

10. Quality is implemented with a total system connected with customers and suppliers. What differentiates the quality leaders from the followers is quality discipline and clear quality work processes to which men and women throughout the organization are committed to its implementation.

## UNIT - III

### STRATEGIC TOOLS FOR TQM

#### 7 BASIC QUALITY TOOLS FOR PROCESS IMPROVEMENT

1. **Cause-and-effect diagram** (also called Ishikawa or fishbone diagrams): Identifies many possible causes for an effect or problem and sorts ideas into useful categories.

**Cause-and-Effect Diagrams** - 1943 by Mr. Kaoru Ishikawa at the University of Tokyo

**Purpose:** One important part of process improvement is continuously striving to obtain more information about the process and its output. Cause-and-effect diagrams allow us to do not just that, but also can lead us to the root cause, or causes, of problems.

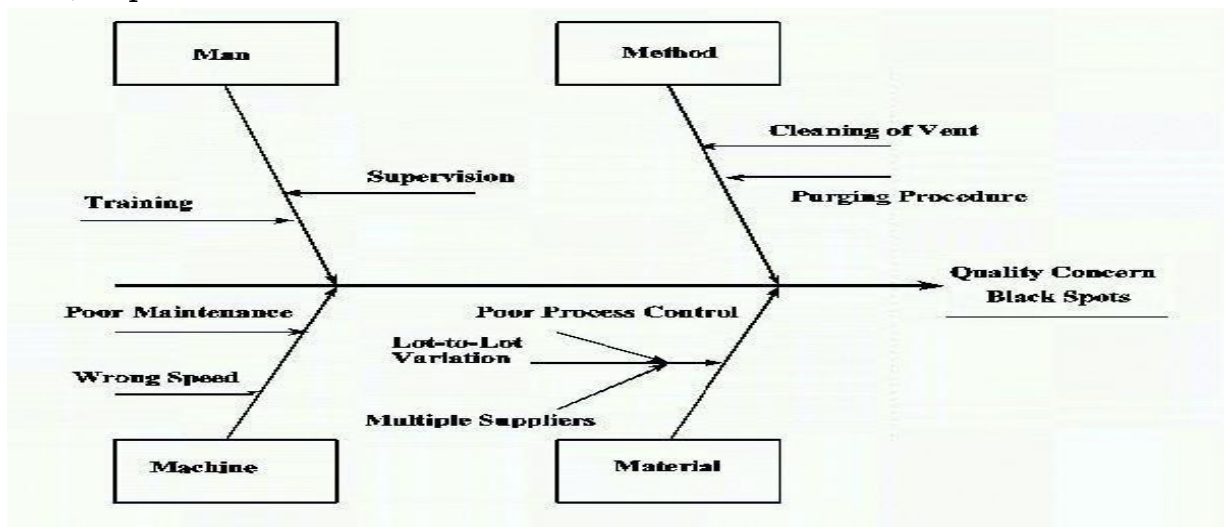

#### **Constructing the Cause-and-Effect Diagram:**

Step 1: Select the team members and a leader. Team members knowledgeable about the quality. Team members focus on the problem under investigation.

Step 2: Write the problem statement on the right hand side of the page, and draw a box around it with an arrow running to it. This quality concern is now the effect.

Step 3: Brain-storming. The team members generate ideas as to what is causing the effect.

Step 4: This step could be combined with step 3. Identify, for each main cause, its related sub-causes that might affect our quality concern or problem (our Effect). Always check to see if all the factors contributing to the problem have been identified. Start by asking why the problem exists.

Step 5: Focus on one or two causes for which an improvement action(s) can be

developed using other quality tools such as Pareto charts, check sheets, and other gathering and analysis tools.

2. **Check sheet:** A structured, prepared form for collecting and analyzing data; a generic tool that can be adapted for a wide variety of purposes.

Defect Types? Event occurrence	Events							Total
	Sun	Mon	Tue	Wed	Thur	Fri	Sat	
Supplied parts rusted		✓✓✓ ✓✓✓ ✓✓	✓✓✓✓ ✓	✓✓✓✓	✓✓			19
Misaligned Weld			✓✓✓			✓✓		5
Improper Test Procedure		✓		✓✓				3
Wrong Part Issued					✓✓			2
Film on Parts				✓✓✓✓		✓✓		6
Voids in Casting								0
Incorrect Dimensions								0
Adhesive Failure					✓			1
Masking Insufficient								0
Spray Failure				✓✓✓✓				4
<i>Total</i>		9	8	14	5	4	0	40

The **check sheet** is a simple document that is used for collecting data in real-time and at the location where the data is generated. The document is typically a blank form that is designed for the quick, easy, and efficient recording of the desired information, which can be either quantitative or qualitative. When the information is quantitative, the check sheet is sometimes called a [tally sheet](#).

A defining characteristic of a check sheet is that data is recorded by making marks (“checks”) on it. A typical check sheet is divided into regions, and marks made in different regions have different significance. Data is read by observing the location and number of marks on the sheet. 5 Basic types of Check Sheets:

- *Classification:* A trait such as a defect or failure mode must be classified into a category.
- *Location:* The physical location of a trait is indicated on a picture of a part or item being evaluated.
- *Frequency:* The presence or absence of a trait or combination of traits is indicated. Also number of occurrences of a trait on a part can be indicated.
- *Measurement Scale:* A measurement scale is divided into intervals, and measurements are indicated by checking an appropriate interval.

- *Check List:* The items to be performed for a task are listed so that, as each is accomplished, it can be indicated as having been completed.

3. **Control chart:** Graph used to study how a process changes over time. Comparing current data to historical control limits leads to conclusions about whether the process variation is consistent (in control) or is unpredictable (out of control, affected by special causes of variation).

Control charts have long been used in manufacturing, stock trading algorithms, and process improvement methodologies like Six Sigma and Total Quality Management (TQM). The purpose of a control chart is to set upper and lower bounds of acceptable performance given normal variation. In other words, they provide a great way to monitor any sort of process you have in place so you can learn how to improve your poor performance and continue with your successes.

The control chart serves to “sound the alarm” when a process shifts (for instance, a machine suddenly breaking on a factory floor) or if someone has a breakthrough that needs to be documented and standardized across the larger organization. Simply put (without taking anomalies into consideration).

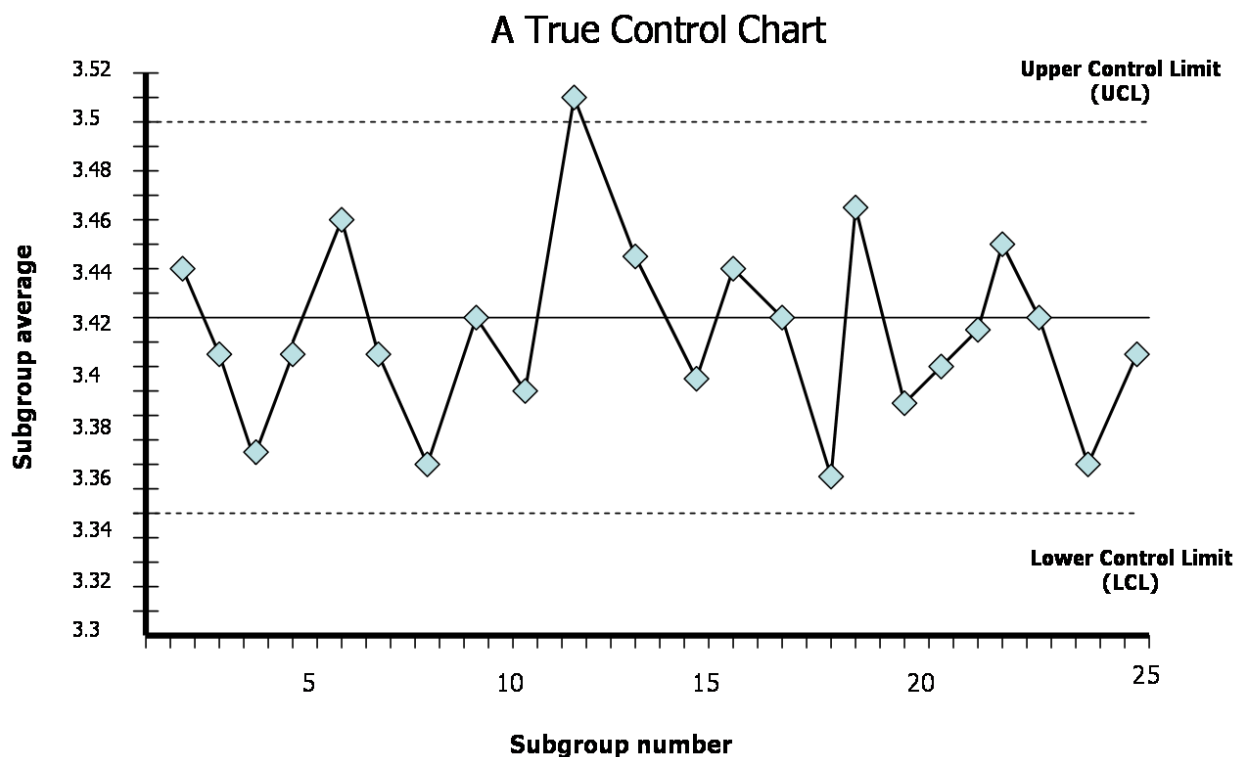

4. **Histogram:** The most commonly used graph for showing frequency distributions, or how often each different value in a set of data occurs.

Error Causes	Total		Serious		Moderate		Minor	
	No.	%	No.	%	No.	%	No.	%
IES	205	22%	34	27%	68	18%	103	24%
MCC	156	17%	12	9%	68	18%	76	17%
IDS	48	5%	1	1%	24	6%	23	5%
VPS	25	3%	0	0%	15	4%	10	2%
EDR	130	14%	26	20%	68	18%	36	8%
ICI	58	6%	9	7%	18	5%	31	7%
EDL	45	5%	14	11%	12	3%	19	4%
IET	95	10%	12	9%	35	9%	48	11%
IID	36	4%	2	2%	20	5%	14	3%
PLT	60	6%	15	12%	19	5%	26	6%
HCI	28	3%	3	2%	17	4%	8	2%
MIS	56	6%	0	0%	15	4%	41	9%
<b>Total</b>	<b>942</b>	<b>100%</b>	<b>128</b>	<b>100%</b>	<b>379</b>	<b>100%</b>	<b>435</b>	<b>100%</b>

1. Incomplete or erroneous specification (IES)
2. Misinterpretation of customer communication (MCC)
3. Intentional deviation from specifications (IDS)
4. Violations of programming standards. (VPS)
5. Error in data representations (EDR)
6. Inconsistent component interface (ICI)
7. Error in design logic (EDL)
8. Incomplete or erroneous testing (IET)
9. Inaccurate or inconsistent documentation (IID)
10. Error in programming language translation of design (PLT)
11. Ambiguous or inconsistent human/computer interface (HCI)
12. Miscellaneous (MIS)

**Usage of histogram:**

Let’s see usage of Histogram in context of “Plan Quality Management” and “Control Quality” for your The Project Management Professional (PMP examination).

- **In “Plan Quality Management”** a Histogram serves as a preventive approach to improve processes. We use historical data to identify categories of causes effecting most. Based on effecting most categories, we select processes to improve. For example due to higher frequencies in IES, MCC and EDR, we may select improvements in “Collect Requirement”, and “Define Scope” processes.



- **Using “Control Quality”** we identify causes of poor performance help in improving processes and their work products. In this way, causes of poor performance analysis make Histogram a powerful tool to take corrective actions.

5. **Pareto chart:** A bar graph that shows which factors are more significant.

Pareto analysis is a technique for recording and analysing information relating to a problem or cause, which easily enables the most significant aspects to be identified.

A Pareto diagram is a special form of vertical bar chart, or column chart, which allows the information to be visually displayed.

#### **When to use it**

- ❖ Separating the 'vital few' from the 'useful many' problems, (80/20 rule).
- ❖ Selecting major problem areas
- ❖ Identifying major effects and causes

#### **What does it achieve?**

“First things first” is the thought behind the Pareto diagram; the properly constructed diagram should suggest on which error or activity resources should be used first to make the best improvement.

Very often the simple process of arranging data may suggest something of importance that would otherwise have gone unnoticed. Selecting classifications, tabulating data, ordering data, and constructing the Pareto diagram have often served a useful purpose in problem investigation.

The communication process between people takes on many forms, and Pareto diagrams are a form of language using a display in a commonly understood format. The continued use of the Pareto diagram enhances communication between members of staff and through all levels of management.

#### **Key steps**

- ❖ List the activities to be analysed
- ❖ Calculate totals
- ❖ Order totals
- ❖ Draw the Pareto diagram
- ❖ Interpret results

#### **Pareto Diagram example**

# Pareto Chart

Table 1												
Player	Sachin	Rajan	Mukul	Gautam	Karan	Bhuvan	Ravi	Wasim	Krishan	Nasim	Sunil	Total
Runs Scored	15	111	65	12	85	10	20	45	5	3	4	375

Table 2			
Player	Runs Scored	Cumulative Score	Cum.% Score
Rajan	111	111	29.60
Karan	85	196	52.27
Mukul	65	261	69.60
Wasim	45	306	81.60
Ravi	20	326	86.93
Sachin	15	341	90.93
Gautam	12	353	94.13
Bhuvan	10	363	96.80
Krishan	5	368	98.13
Sunil	4	372	99.20
Nasim	3	375	100.00

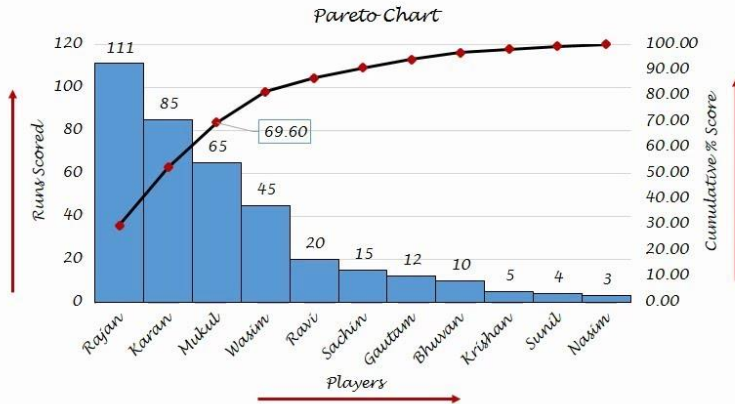

[www.shakehandwithlife.in](http://www.shakehandwithlife.in)

## Difference between Pareto Chart and Histogram:

Histogram	Pareto Chart
The Histogram is a kind of bar chart showing a distribution of variables or causes of problems.	A Pareto chart is a specific type of histogram that represents the causes of problems by their influence. It is a useful tool to prioritize corrective action as errors with the greatest impact displayed in descending order of frequency.
A histogram represents cause of a problem as a column and the frequency of each cause of problem as the height of the column.	In Pareto chart, an arc representing the cumulative percentage of frequencies of causes also included.

6. **Scatter diagram:** Graphs pairs of numerical data, one variable on each axis, to look for a relationship.

# Scatter Chart

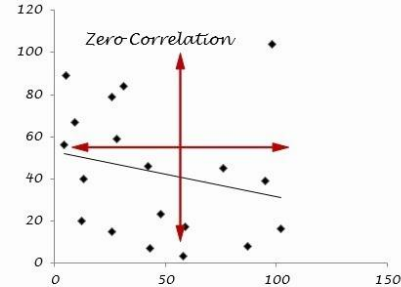
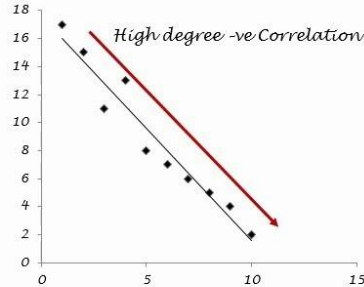
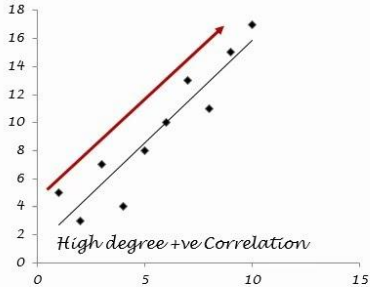
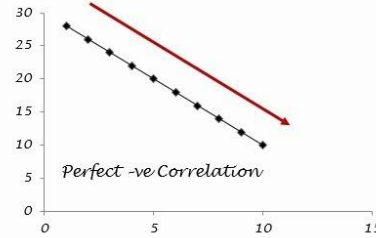
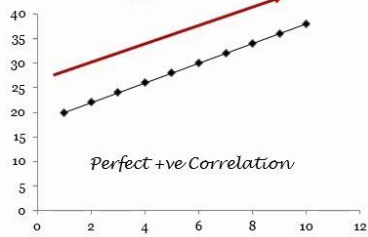

[www.shakehandwithlife.in](http://www.shakehandwithlife.in)

Also called: scatter plot, X-Y graph

The scatter diagram graphs pairs of numerical data, with one variable on each axis, to look for a relationship between them. If the variables are correlated, the points will fall along a line or curve. The better the correlation, the tighter the points will hug the line. This cause analysis tool is considered one of the seven basic quality tools.

## WHEN TO USE A SCATTER DIAGRAM

- ❖ When you have paired numerical data
- ❖ When your dependent variable may have multiple values for each value of your independent variable
- ❖ When trying to determine whether the two variables are related, such as:
  - When trying to identify potential root causes of problems
  - After brainstorming causes and effects using a fishbone diagram to determine objectively whether a particular cause and effect are related
  - When determining whether two effects that appear to be related both occur with the same cause
  - When testing for autocorrelation before constructing a control chart

## SCATTER DIAGRAM PROCEDURE

1. Collect pairs of data where a relationship is suspected.
2. Draw a graph with the independent variable on the horizontal axis and the dependent variable on the vertical axis. For each pair of data, put a dot or a symbol where the x-axis value intersects the y-axis value. (If two dots fall together, put them side by side, touching, so that you can see both.)

**Dr.N.R.Saravanan**, MBA, MBA, PGDHRM, MA (Yoga), M.Phil, Ph.D.,

Asst. Professor – Dept. of Management, Bon Secours College for Women, Thanjavur

3. Look at the pattern of points to see if a relationship is obvious. If the data clearly form a line or a curve, you may stop because variables are correlated. You may wish to use regression or correlation analysis now. Otherwise, complete steps 4 through 7.

❖ Divide points on the graph into four quadrants. If there are  $X$  points on the graph:

- Count  $X/2$  points from top to bottom and draw a horizontal line.
- Count  $X/2$  points from left to right and draw a vertical line.
- If number of points is odd, draw the line through the middle point.

4. Count the points in each quadrant. Do not count points on a line.

5. Add the diagonally opposite quadrants. Find the smaller sum and the total of points in all quadrants.

$A$  = points in upper left + points in lower right

$B$  = points in upper right + points in lower left

$Q$  = the smaller of  $A$  and  $B$

$N = A + B$

- If  $Q$  is less than the limit, the two variables are related.
- If  $Q$  is greater than or equal to the limit, the pattern could have occurred from random chance.

## 7. Stratification (also known as Flow Chart and/or Run Chart)

A technique that separates data gathered from a variety of sources so that patterns can be seen (some lists replace "stratification" with "flowchart" or "run chart").

Stratification is a way to organize data, and in particular of separating data into meaningful groups. Stratification is also known as a flow chart or run chart.

In stratification, you should include each data point in only one group, and you should leave no data point(s) out.

Below is an example of stratification.

### WHEN TO USE STRATIFICATION?

- Before collecting data
- When data come from several sources or conditions, such as shifts, days of the week, suppliers, or population groups
- When data analysis may require separating different sources or conditions

Here are examples of different sources that might require data to be stratified:

- Equipment
- Shifts
- Departments
- Materials
- Suppliers

- Day of the week
- Time of day
- Products

### **STRATIFICATION PROCEDURE**

1. Before collecting data, consider which information about the sources of the data might have an effect on the results. Set up the data collection so that you collect that information as well.
2. When plotting or graphing the collected data on a scatter diagram, control chart, histogram, or other analysis tool, use different marks or colors to distinguish data from various sources. Data that are distinguished in this way are said to be "stratified."
3. Analyze the subsets of stratified data separately. For example, on a scatter diagram where data are stratified into data from source 1 and data from source 2, draw quadrants, count points, and determine the critical value only for the data from source 1, then only for the data from source 2.

### **THE NEW SEVEN TOOLS**

The seven management and planning tools have their roots in operations research work done after World War II and the Japanese total quality control (TQC) research.

1. Affinity Diagram [KJ method]
2. Interrelationship diagram
3. Tree diagram
4. Prioritization matrix
5. Matrix diagram or quality table
6. Process decision program chart
7. Activity network diagram

#### **1. Affinity Diagram [KJ method]**

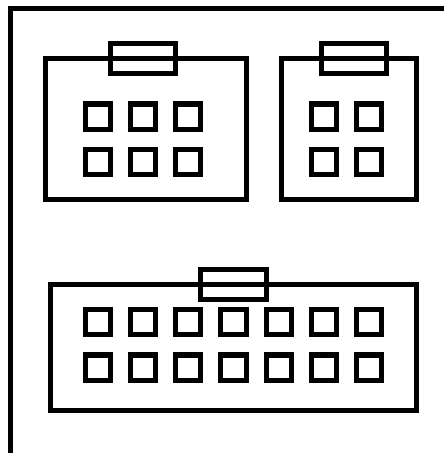

Affinity diagrams are a special kind of brainstorming tool that organize large amount of disorganized data and information into groupings based on natural relationships.

It was created in the 1960s by the Japanese anthropologist Jiro Kawakita. It is also known as KJ diagram, after Jiro Kawakita. An affinity diagram is used when:

1. You are confronted with many facts or ideas in apparent chaos.
2. Issues seem too large and complex to grasp.

## 2. Interrelationship diagram

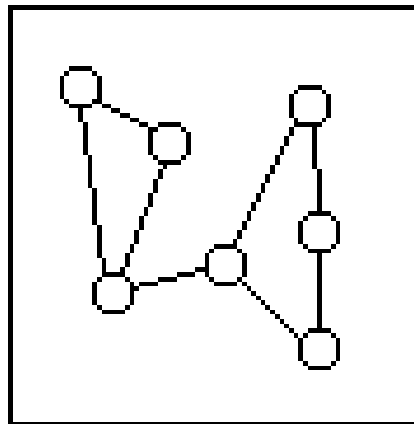

Interrelationship diagrams (IDs) displays all the interrelated cause-and-effect relationships and factors involved in a complex problem and describes desired outcomes. The process of creating an interrelationship diagram helps a group analyze the natural links between different aspects of a complex situation.

## 3. Tree diagram

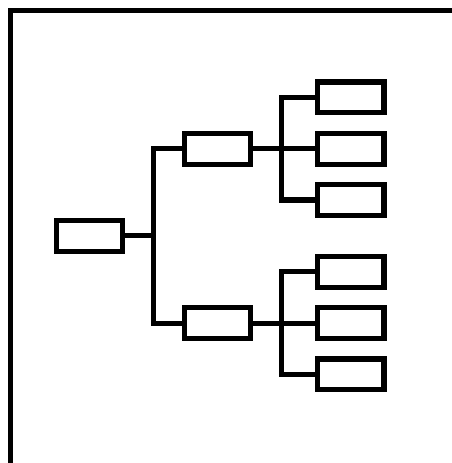

This tool is used to break down broad categories into finer and finer levels of detail. It can map levels of details of tasks that are required to accomplish a goal or solution or task. Developing a tree diagram directs concentration from generalities to specifics.

**4. Prioritization matrix**

	a	b	c	d	e	f
1						
2						
3						
4						
5						
6						

This tool is used to prioritize items and describe them in terms of weighted criteria. It uses a combination of tree and matrix diagramming techniques to do a pair-wise evaluation of items and to narrow down options to the most desired or most effective. Popular applications for the prioritization matrix include return on investment (ROI) or cost-benefit analysis (investment vs. return), time management matrix (urgency vs. importance), etc.

**5. Matrix diagram or quality table**

	a	b	c	d	e	f
1						
2						
3						
4						
5						
6						

This tool shows the relationship between two or more sets of elements. At each intersection, a relationship is either absent or present. It then gives information about the relationship, such as its strength, the roles played by various individuals or measurements. The matrix diagram enables you to analyze relatively complex situations by exposing interactions and dependencies between things. Six differently shaped matrices are possible: L, T, Y, X, C, R and roof-shaped, depending on how many groups must be compared.

## 6. Process decision program chart

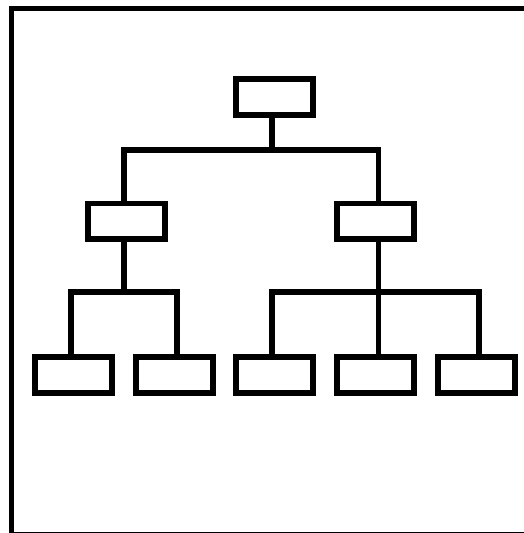

A useful way of planning is to break down tasks into a hierarchy, using a tree diagram. The process decision program chart (PDPC) extends the tree diagram a couple of levels to identify risks and countermeasures for the bottom level tasks. Different shaped boxes are used to highlight risks and identify possible countermeasures (often shown as "clouds" to indicate their uncertain nature). The PDPC is similar to the failure modes and effects analysis (FMEA) in that both identify risks, consequences of failure, and contingency actions; the FMEA also rates relative risk levels for each potential failure point.



## 7. Activity network diagram

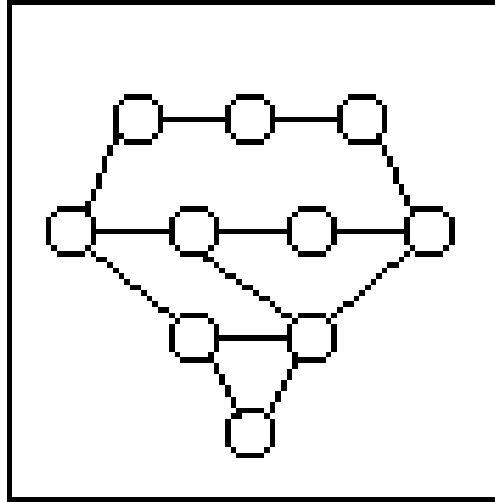

This tool is used to plan the appropriate sequence or schedule for a set of tasks and related subtasks. It is used when subtasks must occur in parallel. The diagram helps in determining the critical path (longest sequence of tasks). The purpose is to help people sequentially define, organize, and manage a complex set of activities.

## **BENCHMARKING**

### **What is benchmarking?**

Benchmarking is a way to go backstage and watch another company's performance from the wings, where all stage tricks and hurried realignments are visible.

In Joseph Juran's 1964 book *Managerial Breakthrough*, he asked the question:

***What is that organizations do that gets result so much better than ours?***

The answer to this question opens door to benchmarking, an approach that is accelerating among many firms that have adopted the total quality management (TQM) philosophy.

### **Levels of Benchmarking**

There are three levels of benchmarking:

1. Internal benchmarking (within the company)
2. Competitive or strategic benchmarking (Industry and competitors)
3. Benchmarking outside the industry.

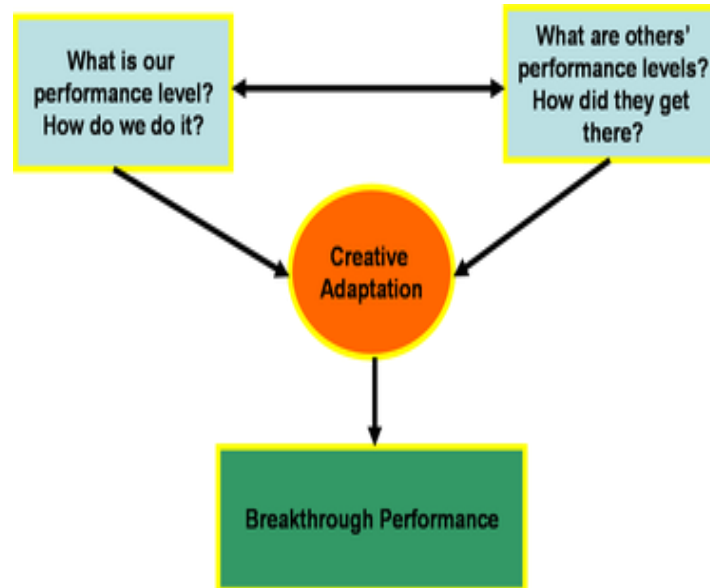

### **Types of benchmarking**

#### **1) Process benchmarking**

The initiating firm focuses its observation and investigation of business processes with a goal of identifying and observing the best practices from one or more benchmark firms. Activity analysis will be required where the objective is to benchmark cost and efficiency; increasingly applied to back-office processes where outsourcing may be a consideration.

#### **2) Financial benchmarking**

Performing a financial analysis and comparing the results in an effort to assess your overall competitiveness.

#### **3) Performance benchmarking**

Allows the initiator firm to assess their competitive position by comparing products and services with those of target firms.

#### **4) Product benchmarking**

The process of designing new products or upgrades to current ones. This process can sometimes involve reverse engineering which is taking apart competitors products to find strengths and weaknesses.

#### **5) Strategic benchmarking**

Involves observing how others compete. This type is usually not industry specific meaning it is best to look at other industries.

#### **6) Functional benchmarking**

A company will focus its benchmarking on a single function in order to improve the operation of that particular function. Complex functions such as Human Resources, Finance and Accounting and Information and Communication

Technology are unlikely to be directly comparable in cost and efficiency terms and may need to be disaggregated into processes to make valid comparison.

### **Procedure of benchmarking**

The following is an example of a typical shorter version of the methodology:

#### **1. Identify your problem areas**

Because benchmarking can be applied to any business process or function, a range of research techniques may be required. They include: informal conversations with customers, employees, or suppliers; exploratory research techniques such as focus groups; or in-depth marketing research, quantitative research, surveys, questionnaires, re-engineering analysis, process mapping, quality control variance reports, or financial ratio analysis. Before embarking on comparison with other organizations it is essential that you know your own organization's function, processes; base lining performance provides a point against which improvement effort can be measured.

#### **2. Identify other industries that have similar processes**

For instance if one were interested in improving hand offs in addiction treatment he/she would try to identify other fields that also have hand off challenges. These could include air traffic control, cell phone switching between towers, transfer of patients from surgery to recovery rooms.

#### **3. Identify organizations that are leaders in these areas**

Look for the very best in any industry and in any country. Consult customers, suppliers, financial analysts, trade associations, and magazines to determine which companies are worthy of study.

#### **4. Survey companies for measures and practices**

Companies target specific business processes using detailed surveys of measures and practices used to identify business process alternatives and leading companies. Surveys are typically masked to protect confidential data by neutral associations and consultants.

#### **5. Visit the "best practice" companies to identify leading edge practices**

Companies typically agree to mutually exchange information beneficial to all parties in a benchmarking group and share the results within the group.

#### **6. Implement new and improved business practices**

Take the leading edge practices and develop implementation plans which include identification of specific opportunities, funding the project and selling the ideas to the organization for the purpose of gaining demonstrated value from the process.

## **BUSINESS PROCESS RE-ENGINEERING (BPR)**

Business process re-engineering (BPR) is a business management strategy, originally pioneered in the early 1990s, focusing on the analysis and design of workflows and business processes within an organization. BPR aimed to help organizations fundamentally rethink how they do their work in order to improve customer service, cut operational costs, and become world-class competitors.

BPR seeks to help companies radically restructure their organizations by focusing on the ground-up design of their business processes. According to early BPR proponent Thomas H. Davenport (1990), a business process is a set of logically related tasks performed to achieve a defined business outcome. Re-engineering emphasized a holistic focus on business objectives and how processes related to them, encouraging full-scale recreation of processes rather than iterative optimization of sub-processes. Business process reengineering is also known as business process redesign, business transformation, or business process change management.

Business process can be defined as "a set of logically related tasks performed to achieve a defined business outcome." It is "a structured, measured set of activities designed to produce a specified output for a particular customer or market." Improving business processes is important for businesses to stay ahead of competition in today's marketplace. Over the last 10 to 15 years, companies have been forced to improve their business processes because customers are demanding better products and services. Many companies begin business process improvement with a continuous improvement model. The BPR methodology comprises of developing the business vision and process objectives, identifying the processes to be redesigned, understanding and measuring the existing processes, identifying IT levers and designing and building a prototype of the new process. In this context it can be mentioned that, some of the biggest obstacles faced by reengineering are lack of sustained management commitment and leadership, unrealistic scope and expectations, and resistance to change.

### **Business Process Reengineering (BPR) and Total Quality Management (TQM)**

Total Quality Management and BPR share a cross-functional relationship. Quality specialists tend to focus on incremental change and gradual improvement of processes, while proponents of reengineering often seek radical redesign and drastic improvement of processes. Quality management, often referred to as TQM or continuous improvement, means programs and initiatives, which emphasize incremental improvement in work processes, and outputs over an open-ended period of time. In contrast, reengineering, also known as business process redesign

or process innovation, refers to prudent initiatives intended to achieve radically redesigned and improved work processes in a specific time frame. In contrast to continuous improvement, BPR relies on a different school of thought. The extreme difference between continuous process improvement and business process reengineering lies in where you start from and also the magnitude and rate of resulting changes.

In course of time, many derivatives of radical, breakthrough improvement and continuous improvement have emerged to address the difficulties of implementing major changes in corporations. Leadership is really important for effective BPR deployment, and successful leaders use leadership styles to suit the particular situation and perform their tasks, giving due importance to both people and work. Business process is essentially value engineering applied to the system to bring forth, and sustain the product with an emphasis on information flow. By mapping the functions of the business process, low value functions can be identified and eliminated, thus reducing cost. Alternatively, a new and less costly process, which implements the function of the current process can be developed to replace the present one.

### **The Role of Consultants in BPR projects**

New reengineering teams typically employ the assistance of a consultant for their project. Consultants can play a valuable role in BPR projects. They are objective and immune to internal politics. Having followed the processes before, they provide valuable information and best practices from a wide range of experience. Consultants can also serve as good communication bridge between the team and management, write project documentation, lead the project and facilitate meetings, make presentations to stakeholders and associates, and last but not the least, contribute subject-matter expertise in your organization's work processes.

### **BPR and Information Technology**

Business Process Re-engineering has rapidly developed towards a new management philosophy. The inherent business process orientation changes the perspective of international management from a structural to that of a process view. The re-engineering of business processes is only one aspect of the management of business processes. In particular, the re-engineering of international business processes needs special attention, because the multi-faceted structure of multinational corporations increases the complexity of business processes, there by influencing the options for redesign. Business Process Re-engineering has rapidly developed towards a new management philosophy based upon predecessors like Total Quality Management, Overhead Value Analysis, Kanban or Just-In-Time-Management. Business processes can be re-engineered by

redesigning the steps, by changing the logical and temporal sequence of the steps, or by changing any other characteristics of the process. The role of IT is discussed in contradictory way. Advocates of information systems favor the view that the new technology is an enabler of process re-engineering. IT has to be monitored constantly to determine whether it can generate new process designs or contribute to the performance of a business process. The breakthrough of BPR is closely connected with IT, which opens new dimensions of process reorganization. Moreover, those who take the initiative in process improvement/redesign, influence the role of IT. If the data processing department initiates the process change, then IT will have more of a generator function for new process redesigns. If on the other hand, the top management sets off the change process, then the process will be first restructured and later optimized through IT.

### **SIX SIGMA (6σ)**

Six Sigma is a set of techniques and tools for process improvement. Six Sigma is a quality management methodology used to help businesses improve current processes, products or services by discovering and eliminating defects. The goal is to streamline quality control in manufacturing or business processes so there is little to no variance throughout.

It was introduced by American engineer Bill Smith while working at Motorola in 1980. Six Sigma was trademarked by Motorola in 1993, but it references the Greek letter sigma, which is a statistical symbol that represents a standard deviation. Motorola used the term because a Six Sigma process is expected to be defect-free 99.99966 percent of the time — allowing for 3.4 defective features for every million opportunities. Motorola initially set this goal for its own manufacturing operations, but it quickly became a buzzword and widely adopted standard.

#### **Six Sigma principles**

The goal in any Six Sigma project is to identify and eliminate any defects that are causing variations in quality by defining a sequence of steps around a certain target. The most common examples you'll find use the targets “smaller is better, larger is better or nominal is best.”

Smaller is Better creates an “upper specification limit,” such as having a target of zero for defects or rejected parts.

Larger is Better involves a “lower specification limit,” such as test scores — where the target is 100 percent.

Nominal is Best looks at the middle ground — a customer service rep needs to spend enough time on the phone to troubleshoot a problem, but not so long that they lose productivity.

The process aims to bring data and statistics into the mesh to help objectively identify errors and defects that will impact quality. It's designed to fit a variety of business goals, allowing organizations to define objectives around specific industry needs.

### **Six Sigma DMAIC**

The Six Sigma DMAIC project methodology includes five phases, each represented as a letter in the DMAIC acronym. These include:

- ❖ **Define** the problem, the customer, the project requirements and the ultimate goals and expectations of the customer.
- ❖ **Measure** performance of the current process by establishing a data collection plan to determine defects and gather metrics.
- ❖ **Analyze** the process to establish root cause of variations and defects to identify issues with the current strategy that stand in the way of the end goal.
- ❖ **Improve** the process by eliminating the root causes of defects through innovative solutions.
- ❖ **Control** the new process to avoid falling into old habits and to ensure it stays on track.

### **Six Sigma DMADV**

The Six Sigma DMADV, also known as the Design For Six Sigma (DFSS), includes five stages:

- ❖ **Define** realistic goals that suit the customer's requirements or the business strategy.
- ❖ **Measure** and identify the customer's critical to quality (CTQ) requirements and translate them into clear project goals.
- ❖ Analyze multiple options and alternatives for the customer along with the estimated total life cycle of the project.
- ❖ **Design** the process at a high level before moving onto a more detailed version that will become the prototype to identify errors and make modifications.
- ❖ **Verify** that the final iteration of the product or process is approved by all customers and clients — whether internal or external.

### **Six Sigma implementation roles**

**Executive leadership:** This includes the CEO and other executive management who are charged with developing the vision for Six Sigma implementation. Leaders should also be responsible for encouraging new ideas and supplying the resources to act on innovation.

**Champions:** Typically found in upper management, Champions are the people responsible for acting on executive leadership's vision and acting as mentors to black belts.

**Master Black Belts:** These workers spend all their time on Six Sigma methodology, either by guiding Black or Green Belts or helping Champions. They're picked out by Champions and are tasked with ensuring consistency in the Six Sigma strategy.

**Black Belts:** Working below Master Black Belts, Black Belts are responsible for executing on the Six Sigma strategy and typically act as leaders for specific tasks.

**Green Belts:** Guided by Black Belts, Green Belts are new to the Six Sigma methodology and start learning it while maintaining their other job responsibilities.

### **JIT - JUST IN TIME**

Just-In-Time (JIT) Manufacturing is a philosophy rather than a technique. By eliminating all waste and seeking continuous improvement, it aims at creating manufacturing system that is response to the market needs. Just-in-time manufacturing was a concept introduced to the United States by the Ford motor company.

JIT is a technique in Lean which ensures minimum inventory and naturally better flow in production. TQM is a philosophy to continuously improve the processes with the involvement of people to satisfy or delight our customers.

Without the TQM thinking, companies implement JIT and fail in their journey because any JIT needs a worker involvement, cross functional way of working and a clear culture of continuous improvement. All these are possible only in organizations implementing TQM.

#### **Advantages OF Just-in-Time (JIT)**

JIT inventory systems have several advantages over traditional models. Production runs are short, which means that manufacturers can quickly move from one product to another. Furthermore, this method reduces costs by minimizing warehouse needs. Companies also spend less money on raw materials because they buy just enough resources to make the ordered products and no more.



### **Disadvantages of Just-in-Time (JIT)**

The disadvantages of JIT inventory systems involve potential disruptions in the supply chain. If a raw materials supplier has a breakdown and cannot deliver the goods in a timely manner, this could conceivably stall the entire production process. A sudden unexpected order for goods may delay the delivery of finished products to end clients.

## **QUALITY FUNCTION DEPLOYMENT (QFD)**

### **What is Quality Function Deployment?**

Quality Function Deployment (QFD) is a process and set of tools used to effectively define customer requirements and convert them into detailed engineering specifications and plans to produce the products that fulfill those requirements. QFD is used to translate customer requirements (or VOC) into measurable design targets and drive them from the assembly level down through the sub-assembly, component and production process levels. QFD methodology provides a defined set of matrices utilized to facilitate this progression.

QFD was first developed in Japan by Yoji Akao in the late 1960s while working for Mitsubishi's shipyard. It was later adopted by other companies including Toyota and its supply chain. In the early 1980s, QFD was introduced in the United States mainly by the big three automotive companies and a few electronics manufacturers. Acceptance and growth of the use of QFD in the US was initially rather slow but has since gained popularity and is currently being used in manufacturing, healthcare and service organizations.

### **Why Implement Quality Function Deployment (QFD)**

Effective communication is one of the most important and impactful aspects of any organization's success. QFD methodology effectively communicates customer needs to multiple business operations throughout the organization including design, quality, manufacturing, production, marketing and sales. This effective communication of the Voice of the Customer allows the entire organization to work together and produce products with high levels of customer perceived value. There are several additional benefits to using Quality Function Deployment:

**Customer Focused:** QFD methodology places the emphasis on the wants and needs of the customer, not on what the company may believe the customer wants. The Voice of the Customer is translated into technical design specifications. During the QFD process, design specifications are driven down from machine level to system, sub-system and component level requirements. Finally, the design specifications are controlled throughout the production and assembly processes to assure the customer needs are met.

**VOC Competitor Analysis:** The QFD “House of Quality” tool allows for direct comparison of how your design or product stacks up to the competition in meeting the VOC. This quick analysis can be beneficial in making design decisions that could place you ahead of the pack.

**Shorter Development Time and Lower Cost:** QFD reduces the likelihood of late design changes by focusing on product features and improvements based on customer requirements. Effective QFD methodology prevents valuable project time and resources from being wasted on development of non-value added features or functions.

**Structure and Documentation:** QFD provides a structured method and tools for recording decisions made and lessons learned during the product development process. This knowledge base can serve as a historical record that can be utilized to aid future projects.

## **TAGUCHI'S QUALITY ENGINEERING**

Taguchi methods are statistical methods, sometimes called robust design methods, developed by Genichi Taguchi to improve the quality of manufactured goods, and more recently also applied to engineering, biotechnology, marketing and advertising. Professional statisticians have welcomed the goals and improvements brought about by Taguchi methods, particularly by Taguchi's development of designs for studying variation, but have criticized the inefficiency of some of Taguchi's proposals.

### **Loss functions in the statistical theory**

Traditionally, statistical methods have relied on mean-unbiased estimators of treatment effects: Under the conditions of the Gauss–Markov theorem, least squares estimators have minimum variance among all mean-unbiased linear estimators. The emphasis on comparisons of means also draws (limiting) comfort from the law of large numbers, according to which the sample means converge to the true mean. Fisher's textbook on the design of experiments emphasized comparisons of treatment means.

However, loss functions were avoided by Ronald A. Fisher [clarification needed - loss functions weren't explicitly mentioned yet]

### **Taguchi's use of loss functions**

Taguchi knew statistical theory mainly from the followers of Ronald A. Fisher, who also avoided loss functions. Reacting to Fisher's methods in the design of experiments, Taguchi interpreted Fisher's methods as being adapted for seeking to improve the mean outcome of a process. Indeed, Fisher's work had been largely motivated by programmes to compare agricultural yields under

different treatments and blocks, and such experiments were done as part of a long-term programme to improve harvests.

However, Taguchi realised that in much industrial production, there is a need to produce an outcome on target, for example, to machine a hole to a specified diameter, or to manufacture a cell to produce a given voltage. He also realised, as had Walter A. Shewhart and others before him, that excessive variation lay at the root of poor manufactured quality and that reacting to individual items inside and outside specification was counterproductive.

## **FAILURE MODE AND EFFECT ANALYSIS (FMEA)**

Failure mode and effects analysis (FMEA; often written with "failure modes" in plural) is the process of reviewing as many components, assemblies, and subsystems as possible to identify potential failure modes in a system and their causes and effects. For each component, the failure modes and their resulting effects on the rest of the system are recorded in a specific FMEA worksheet. There are numerous variations of such worksheets. An FMEA can be a qualitative analysis, but may be put on a quantitative basis when mathematical failure rate models are combined with a statistical failure mode ratio database. It was one of the first highly structured, systematic techniques for failure analysis. It was developed by reliability engineers in the late 1950s to study problems that might arise from malfunctions of military systems. An FMEA is often the first step of a system reliability study.

A few different types of FMEA analyses exist, such as:

- ❖ Functional
- ❖ Design
- ❖ Process

- **"Failure modes"** means the ways, or modes, in which something might fail. Failures are any errors or defects, especially ones that affect the customer, and can be potential or actual.
- **"Effects analysis"** refers to studying the consequences of those failures. Failures are prioritized according to how serious their consequences are, how frequently they occur, and how easily they can be detected. The purpose of the FMEA is to take actions to eliminate or reduce failures, starting with the highest-priority ones.

## **WHEN TO USE FMEA?**

When a process, product, or service is being designed or redesigned, after quality function deployment (QFD)

- ❖ When an existing process, product, or service is being applied in a new way
- ❖ Before developing control plans for a new or modified process
- ❖ When improvement goals are planned for an existing process, product, or service
- ❖ When analyzing failures of an existing process, product, or service
- ❖ Periodically throughout the life of the process, product, or service

## **POKA YOKE**

**Poka-yoke** is a Japanese term that means "mistake-proofing" or "inadvertent error prevention". A poka-yoke is any mechanism in any process that helps an equipment operator avoid (yokeru) mistakes (poka). Its purpose is to eliminate product defects by preventing, correcting, or drawing attention to human errors as they occur. The concept was formalised, and the term adopted, by Shigeo Shingo as part of the Toyota Production System.

**Mistake Proofing:** Apply to the process to prevent mistakes from occurring, stop the error from further processing, and warn that the error has occurred.

**Error Proofing:** Apply to design to prevent assembly errors.

### **Zero Defects System**

Failure Mode Effects Analysis (FMEA) application into Error Proofing-Design/Process FMEA

A design FMEA is an analytical technique used by product or process designers as a means to ensure that, to the extent possible, potential failure modes and their associated causes have been considered and addressed. The design must be improved based on the results of the FMEA study. All the design and possible error proofing should be identified during the development of Design Failure Mode Effects Analysis (DFMEA) and integrated into design.

### **Error Proofing Techniques**

**Design For Manufacturability (DFM):** Techniques in designs that cannot be incorrectly manufactured or assembled. This technique also can be used to simplify the design and, therefore, reduce its cost for product.

**Poka-Yoke System:** Set-up devices or inspection techniques that ensure setup is done correctly; for example, produce 100% good parts from the first piece on.

Design Stage: Best opportunity to impact quality and cost.

### **Why Use Error Proofing?**

**Competitive Advantage:** In a global market the cost of quality is part of the competitive advantage. It costs far less to prevent defects from occurring in the first place than to catch them later through inspection and have to rework or repair them.

**Knowledgeable Workers:** When every employee understands the principles of error proofing, work teams can see more easily how defects are generated and can then effectively eliminate them. They can participate in the design and improvement of parts processing and assembly operations in order to prevent defects from occurring. These methods can be employed in the office as well to eliminate errors in paper processes.

**Predictability:** If machines (manual or robotic) include error-proofing devices, then there is assurance that the end product will be defect free. This eliminates inspection and rework operations, as well as scrap.

**Reduced Variation:** Error Proofing devices also ensure that subassembly and assemblies are exactly the same. There will be little chance of part-to-part variation if the machines are designed or modified to prevent errors and their resulting defects. Human error is natural. But sometimes when errors can be traced back to the operator's interaction with the process, there is a tendency to blame the operator. But the root cause of the error is usually failure to account for the possibility of human errors or omissions-by people who design machinery, layouts or operating procedures. Error proofing can correct this.

## **UNIT – IV**

### **QUALITY EDUCATION**

Total Quality Management is a management approach that was instigated in the 1950s and has gradually become popular since the early 1980s. The term 'quality' is at the core of this philosophy. While defining total quality management, scholars took the opportunity to present their perceptions regarding this term in numerous ways; as a result, a good number of definitions appear before us with different connotations. Crosby states that quality management is a methodical way of ensuring that organized activities happen the way they are planned. Short & Rahim define TQM is a proactive approach, to confirm quality into the product, service and design of the process and then to continually improve it.

According to these definitions, TQM is a plan, a systematic approach to ensure quality and continuous improvement. Deming describes TQM is a never-ending cycle of progress in the system of production should change into gaining better performance and quality standards for the product. Yang perceives TQM is a set of practices that focuses on the systematic improvement, satisfying the customers' needs, and decreasing rework. TQM is a system and set of practices which are aimed at relentless quality improvement and better business performance. TQM views an organization as a collection of interrelated processes. It (TQM) is a method by which management and employees are involved in continuous improvement of the production of goods and services. Goetsch and Davis opine that TQM consists of relentless improvement activities, involving everybody in the business in a totally integrated effort towards improving performance at every level. Vinni comments TQM creates such environment in which all the assets are used ingeniously and effectively in order to provide quality service the institution needs to adapt in this fast paced world.

According to Witcher, TQM is the combination of three terms—Total: meaning that one is involved, including customer and suppliers; Quality: indicating that customer needs are met exactly; and Management: indicating that senior executives are committed. Oakland expresses TQM as an approach involving the whole organization for understanding each activity of each individual at each management layer. TQM strives to integrate all organizational functions (marketing, finance, design, engineering, and production, customer service, etc.) to focus on meeting customer needs and organizational objectives. Escrig considers TQM as a strategic action that focuses on managing the total organization to provide products or services that fulfill their customer requirements by utilizing all resources. TQM is the holistic

management approach that incorporates all the organizational activities to satisfy customers' needs and achieving overall organizational objectives as outlined by Kumar et al.

### **Quality Education process with Education**

Michael et al. comment that TQM can be defined as a general management philosophy and a set of tools which allow an institution to pursue a definition of quality and a means for achieving quality, with quality being a continuous improvement as determined by customers' satisfaction with the services they have received. It indicates the flexible aspect of TQM, i.e. it is applicable to any organization and subject to adjustment as per merit of the situation. With the help of TQM, an academic institution would be able to develop its own definition of quality, benchmark, and quality improvement practices in the light of customers' requirement. Meirovich and Romar observe that the findings of the literature on the usefulness of TQM in education are differing. There are some authors who are very much confident about the applicability of TQM in education. According to Srivanci, they believe that the values of TQM are similarly appropriate in higher education.

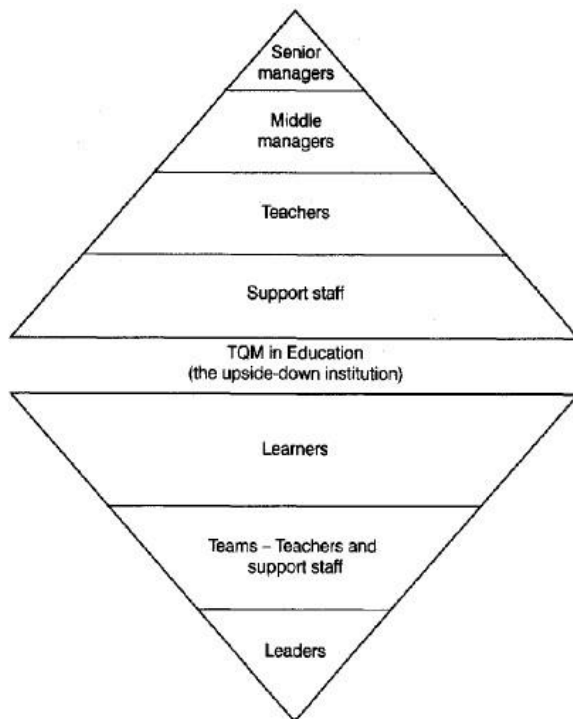

As an approach, TQM represents a permanent shift in an institution's focus away from short-term expediency to the long-term quality improvement. Herman and Herman (1994) stated three levels of application of quality management in education. The first level is to the management process of a

school, including strategic planning, recruiting and staff development, deploying resources, and alignment of what is taught, how it is taught, and how it is assessed. The next level is teaching quality to students. Students are recognized as both customer and workers in the educational system. Administrators need to involve students in their own education by training them to evaluate the learning process and accept responsibility for their learning. Robert and Robert (1998) addressed the most influential factor in success or failure of a TQM implementation effort is universal endorsement. If management is not completely sold on TQM, it is unlikely that an implementation effort will be successful. Endorsing TQM represents a fundamental change in the way. Less than full support by anyone in the chain of authority essentially condemns the effort to failure.

- |  |
|--|
| <ol style="list-style-type: none"> <li>1. Create constancy of purpose</li> <li>2. Adopt a new philosophy</li> <li>3. Cease dependence on mass inspection</li> <li>4. End the practice of conducting on cost alone</li> </ol>                         |
| <ol style="list-style-type: none"> <li>5. Constantly improve process</li> <li>6. Institute training</li> <li>7. Institute leadership</li> </ol>  |
| <ol style="list-style-type: none"> <li>8. Drive out fear</li> <li>9. Break down barriers</li> <li>10. Avoid obsession with goals and slogans</li> <li>11. Eliminate numerical quotas</li> <li>12. Remove barriers to pride of workmanship</li> </ol> |
| <ol style="list-style-type: none"> <li>13. Organization-wide involvement</li> <li>14. Define management's responsibilities to make it happen</li> </ol>  |

TQM is usually accomplished by a series of small-scales incremental projects. The philosophy of TQM is large-scale, inspirational and all-embracing, but its practical implementation is small-scale, highly practical and incremental. Solid and lasting change is based on a long series of small and achievable projects (Edward 3rd, 2002). TQM requires the change entirely for organization. Change of culture is notoriously difficult to bring about and takes into implement. It requires a change of attitudes and working methods. Two things are required for staff to produce quality. First, staff needs a suitable environment in which to work. The tools of trade, system and procedures should aid them in doing their jobs. The environment that surrounds staff has



a profound effect on their ability to do their job properly and effectively. Second, encouragement and recognition of success and achievement should be deserved from leaders who can appreciate their achievement and coach them to greater success.

### **EARLIER EFFORTS OF IMPLIMENTATION OF TQM IN EDUCATION**

TQM in education surfaced in 1988 at Mt. Edgcombe High School in Sitka, Alaska. When David Langford, the school's technology teacher/coordinator, applied total quality concepts in his classes. TQM has become increasingly popular in education, as evidenced by the plethora of books and journal articles since 1990. TQM has also spread into mainstream of educational organizations. The association for supervision and curriculum development, for example devoted its entire November, 1992 issue of its Journal, "Educational Leadership" to quality movement in education. In support of the TQM initiatives in education, Crawford and Shutler (1999) applied Crosby model to suggest a practical strategy for using TQM principles in education.

Their strategy focused on the quality of teaching system used rather than on students, examination results. They argue that examinations are a diagnostic tool for assuring the quality of the teaching system. To satisfy the educational needs of students, continuous improvement efforts need to be directed to curriculum and delivery services. From such a perspective, various root causes of quality system failure in education have been identified. These include poor inputs, poor delivery services, lack of attention paid to performance standards and measurements, unmotivated staff and neglect of student's skill, Ali and Zairi (2005).

### **REASONS TO APPLY TQM IN EDUCATION**

A lot of literature available points to a growing interest in applying TQM in education for a wide variety of reasons, Thakkar et al. (2006). Some of the reasons include pressures from industry for continuous upgrading of academic standards with changing technology; government schemes with allocation of funds, which encourage research and teaching in the field of quality; increasing competition between various private and government academic institutions and reduction in the pool of funds for research and teaching, implying that only reputable institutions will have a likely chance of giving access to various funds. According to Crosby (1984) unless strategy is focused on the quality of the teaching system and improvement, goal of TQM cannot be fulfilled. TQM in education cannot be accomplished without everyone in the organization from top to bottom being committed to achieve results a passion for quality and decisions based on performance data, Kaufman, (1992). According to Corrigan (1995), unless an organization builds a customer driven, learning organization

dedicated to total customer satisfaction TQM cannot be successful. “A set of fundamental core values forming building blocks of proposed TQM framework is leadership and quality cultures continuous improvement and innovation in educational process; employee participation; and development; fast response and management of information customer-driven quality and partnership development; both internally externally”, Juran and Gryna (1980).

### **FOR SUCCESSFUL IMPLEMENTATION IN EDUCATION**

For the successful implementation of TQM in education quality circles are to be formed. A quality circle consists of small groups of people that meet on a regular basis to discuss problems to seek solutions and to cooperate with management in the implementation of those solutions. Quality circles utilize organized approaches to problem solving, operate on the principle that employee participation in decision making and problem solving improves the quality of work. In education quality deals with monitoring and identifying the areas that affect the levels of teachings. The past few decades were considered pioneering work on educational leadership, Bensimon and Neuman (1993), the leadership component deal with examining senior management personal of leadership and involvement in creating and sustaining a customer focus, clear goals, high expectations and a leadership system that would perform excellently.

It also examines leadership system and policies internally that would impact staff and students and public responsibilities establishing partnerships with industry parents and general community externally. Improvements in leadership effectiveness could be achieved through a participative management style that includes inputs from a comprehensive 360 degree feedback system from these internal and external stakeholders. The strategic planning of this element would examine how the institution sets strategic directions and how it determines key plan requirements with a primary focus on students satisfaction. This element examines the key aspects of process management including learner focused education design, education delivery services and business operations. It examines how key processes are innovatively and continuously improved. The performance results of this element would examine student performance and improvement using key measures and indicators. This element examines how staff development and training is aligned along the objectives of the institution.

### **QUALITY OBJECTIVES AND QUALITY POLICY**

A quality system is the method used to ensure that the quality level of a product or service is maintained. The system documentation can be viewed as as hierarchy containing four tiers, as shown in the following illustrations:

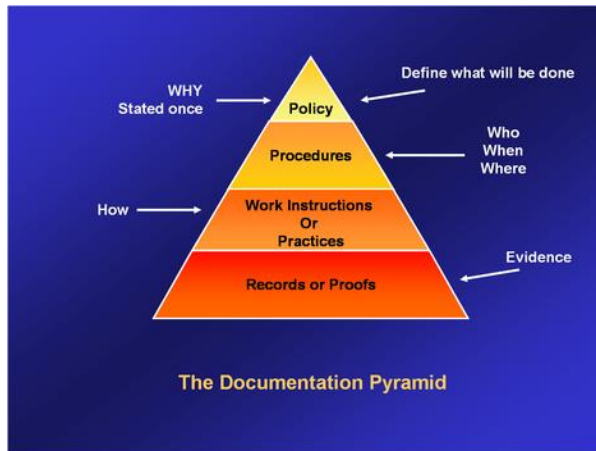

### **Define the term strategy?**

In order to understand the concept of strategic management, first we need to understand the literal meaning of the word “strategy”. The definition is mentioned below:

1. The science and art of using all the forces of a nation to execute approved plans as effectively as possible during peace or war. The science and art of military command as applied to the overall planning and conduct of large-scale combat operations.
2. A plan of action resulting from strategy or intended to accomplish a specific goal.
3. The art or skill of using stratagems in endeavors such as politics and business

### **What is the relation of Strategic Planning and Total Quality Management?**

When an organizations chooses to make quality a major competitive edge (differentiation), it becomes the central issue in strategic planning. This is especially reflected in vision, mission and policy guidelines of an organization.

An essential idea behind strategic quality planning is that the product is customer value rather than a physical product or service. This feat cannot be achieved unless an organization creates a culture of quality and no strategy and plan can be worthwhile unless it is carefully implemented.

### **What do you understand by the term quality statements? Elaborate them with examples.**

Quality statements are part of strategic planning process and once developed, are occasionally reviewed and updated.

There are three types of quality statements:

1. Vision statement
2. Mission statement
3. Quality policy statement

The utilization of these statements varies from organization to organization. Small organization may use only the quality policy statement

**1. Vision Statement:** The vision statement is a short declaration what an organization aspires to be tomorrow. A vision statement, on the other hand, describes how the future will look if the organization achieves its mission.

Successful visions are timeless, inspirational, and become deeply shared within the organization, such as:

- ❖ IBM's Service
- ❖ Apple's Computing for the masses
- ❖ Disney theme park's the happiest place on the earth, and
- ❖ Polaroid's instant photography

**2. Mission Statement:** A mission statement concerns what an organization is all about. The statement answers the questions such as: who we are, who are our customers, what do we do and how do we do it. This statement is usually one paragraph or less in length, easy to understand, and describes the function of the organization. It provides clear statement of purpose for employees, customers, and suppliers.

An example of mission statement is:

Ford Motor Company is a worldwide leader in automatic and automotive related products and services as well as the newer industries such as aerospace, communications, and financial services. Our mission is to improve continually our products and services to meet our customers' needs, allowing us to prosper as a business and to provide a reasonable return on to our shareholders, the owners of our business.

**3. Quality Policy Statement:** The quality policy is a guide for everyone in the organization as to how they should provide products and services to the customers. It should be written by the CEO with feedback from the workforce and be approved by the quality council. A quality policy is a requirement of ISO 9000.

A simple quality policy is:

Xerox is a quality company. Quality is the basic business principle for Xerox. Quality means providing our external and internal customers with innovative products and services that fully satisfy their requirements. Quality is the job of every employee.

## **QUALITY PLANNING**

### **WHAT IS A QUALITY PLAN?**

A quality plan is a document, or several documents, that together specify quality standards, practices, resources, specifications, and the sequence of activities relevant to a particular product, service, project, or contract. Quality plans should define:

Objectives to be attained (for example, characteristics or specifications, uniformity, effectiveness, aesthetics, cycle time, cost, natural resources, utilization, yield, dependability, and so on)

- Steps in the processes that constitute the operating practice or procedures of the organization
- Allocation of responsibilities, authority, and resources during the different phases of the process or project
- Specific documented standards, practices, procedures, and instructions to be applied
- Suitable testing, inspection, examination, and audit programs at appropriate stages
- A documented procedure for changes and modifications to a quality plan as a process is improved
- A method for measuring the achievement of the quality objectives
- Other actions necessary to meet the objectives

At the highest level, quality goals and plans should be integrated with overall strategic plans of the organization. As organizational objectives and plans are deployed throughout the organization, each function fashions its own best way for contributing to the top-level goals and objectives.

At lower levels, the quality plan assumes the role of an actionable plan. Such plans may take many different forms depending on the outcome they are to produce. Quality plans may also be represented by more than one type of document to produce a given outcome.



## HOW TO WRITE A QUALITY PLAN

**Quality Assurance** or **Quality Control** plans evaluate and/or modify an organization's procedures to help ensure they provide the desired results. Quality control plans are often viewed as a set of instructions that should be followed. They document the planning, implementation, and assessment procedures for a project, as well as any QA or QC activities.

Some areas may be more detailed than others, based on the project, process, or organization's needs. It is important to note that each plan is unique based on the organization's needs and their Quality Management System (QMS). However, quality control plans should always have a structure that permits improvements to the plan. This allows employees to offer input on how to improve efficiency and quality. In addition, the plan should be reviewed by others periodically, including stakeholders, to ensure the plan is comprehensive.



Quality control plans generally include detailed information on:

- An overview or introduction of the project or process detailing the background, need, scope, activities, and important dates or deadlines
- The organizational structure or org chart detailing necessary team members, including external vendors
- Each team member's responsibilities and qualifications necessary to fulfill stated duties
- Work verification (e.g., who is responsible for carrying out a task, as well as who is responsible for checking the work)
- Supplier standards (e.g., specify the standards the prospective suppliers must meet before they can bid on a contract, such as ISO 9001:2015)
- A list of qualified suppliers

- Testing parameters
- Performance standards and how performance will be documented
- Acceptance criteria
- Deliverables
- A feedback mechanism for internal and/or external customer feedback
- Quality control procedures
- Audits
- Training (e.g., overview, job-specific, or refresher training)
- Corrective action and preventive actions, including the person(s) responsible for CAPA
- Suggested corrective action
- Required notifications
- Any references or related materials, including performance ratings or performance reports

## **QUALITY INFORMATION FEEDBACK**

### **Customer Feedback:**

Should be continually solicited and monitored: Customer Feedback should be continuously solicited as customer preferences keep on changing. Let us remember those days when the original red Lifebuoy was selling like hot cake. Now people's preferences have changed. The organization has come up with many variations of Lifebuoy. The basic USP remains the same, 'health and hygiene' but concepts of, beauty and healthy skin is thrown in to satisfy the changed customer needs.

### **Customer complaints (feedback)**

Customer feedback must be continuously solicited and monitored to reduce the dissatisfied customers as much as possible.

### **Purpose of Feedback:**

**Discover Customer Dissatisfaction:** The feedback helps to know how satisfied or dissatisfied the customer is. A customer who does not complain and switches to another brand is more dangerous than a customer who complains. Customer dissatisfaction can be a big eye opener and help discover what more needs to be done for a product or service.

**Discover Relative Priorities of Quality:** Certain parameters of quality are more important than others. Whenever planning for a quality goal the organization should prioritize its goals.

**Compare Performance With Competition:** Watching competitor activity is a good learning tool for any organization. This is a way of benchmarking us vis-à-vis others.

**Identify Customer's Needs:** There is a saying that salesman who discovers a customer need before everyone else is more likely to get the sales. The same logic holds for organizations as well. You can always reap the benefits of first mover advantage. Let us take example of Frooti. Probably Frooti is the first brand to identify the Indian taste and to make an effort to cater to that taste. No matter how many drinks with mango flavour has come Frooti remains the numerous undo in its segment.

**Determine Opportunities for Improvement:** Customer feedback also helps an organization in determining about opportunities for improvement.

### **TYPES OF CUSTOMERS**

**Internal Customer:** The customer inside the company are called internal customers

**External Customers:** An external customer is the one who used the product or service or who purchase the products or service or who influences the sale of the product or service.

### **Tools of Customer Feedback:**

- **Comment Card:** This can have simple open questions so that customer can answer it quickly.
- **Customer Questionnaire:** Design of questionnaire is of utmost importance to get timely and relevant information.
- **Focus Groups:** Focus groups are mostly used in B2B set up. Especially in pharmaceuticals industry, key opinion makers are made part of the trial. Their opinion holds sway over doctors of hinterland. It helps them get a word to mouth publicity as well.
- **Toll Free Telephone Numbers**
- **Customer Visits**
- **Report Cards**
- **Social Networking Sites:** There are certain sites where visitors can share good or bad experience with a product or service. These sites give real insight into customer's minds. On other social networking sites, like Twitter and Facebook, people share their experiences and sometimes, unknowingly may give opinion about a company. Now certain companies are having devoted teams to analyse these data.
- **Employee Feedback:**



- **Mass Customization:** Mass customization is another good tool to know about changed preferences. Levi's gives a facility on its website which enables a potential customer to choose certain fabric, colour and design. Once the customer places an order Levi's gets the jeans stitched and delivered at customer's doorstep.

### Service Quality

#### **Organization Level**

**Identify Each Market Segment:** Each market segment has its own dynamics, so customer needs tend to vary as per a market segment. For example in a diverse country like India, customers of north India will have different needs compared to those in south India.

**Write Down The Requirements:** A very good example of chalking out requirements of a particular market is shown during recent launch of a dark chocolate brand by Cadbury's in India. India is hot country so selling dark chocolates has its own issue of logistics management. Cadbury's is supplying these chocolates in insulated boxes to key retailers so that customer can get the right quality of chocolate.

**Communicate The Requirements:** Communicating your quality requirements is a way of convincing the front line people so that they will implement everything as per the original plan. Around 2000 the pharmaceuticals giant Pfizer launched a hepatitis-B vaccine. The product needed to be supplied through cold chain up to the vaccination point. All personnel in sales force were properly educated on this issue to ensure proper implementation of cold chain. This ensured that the product reached the end user at right temperature to provide desired efficacy.

**Organize Processes:** Every process should be well organized to ensure optimum output and resultant benefit to the customer.

### KANO Model

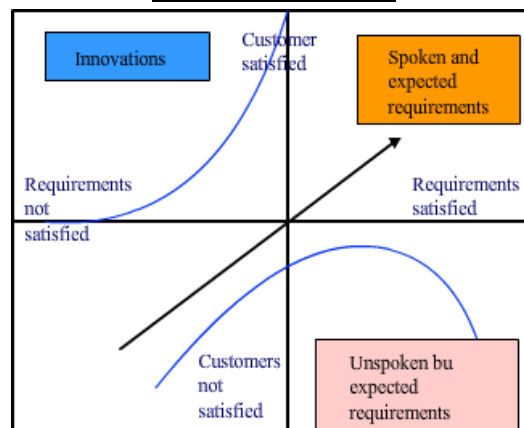

KANO Model

Kano Model is very interesting depiction of how an unsatisfied customer can be turned to a satisfied customer by properly implementing quality goals. In bottom left quadrant lies the most unsatisfied customer. This can be because of many reasons. The product is not fulfilling customer need or the product is not matching his expectations. When the customer moves to the bottom right quadrant then he is just a mute buyer of the product. He may be buying the product because that is his necessity. The product is just fulfilling certain basic needs of the customer. This can be compared by how customers must have been feeling when Bajaj scooter was the only major brand available in the Indian market. People had to choose from some very basic models like Bajaj Chetak, Rajdoot and Yezdi. Then came the onslaught of 100 cc bike. This gave more convenience to customers. In the late nineties many models arrived on the scene and some of them gave real customer delight taking the customer to the top left quadrant of the Kano model.

### **TQM CULTURE**

The origin and development of the quality management discipline as a practice-oriented approach to management has provided a challenge for academic research that aims at discovering the theoretical foundations of total quality management (TQM). The ISO 9000 family of quality standards and quality award criteria have led to the practical development and diffusion of the discipline, and currently they provide the most comprehensive definition for TQM. The Malcolm Baldrige National Quality Award has been selected as the practical definition of TQM for this study. TQM is studied as a cultural phenomenon. The multiple levels of the discipline are identified and analyzed based on Schein's framework for organizational culture. The focus is on the most comprehensive level, the analysis of basic assumptions underlying the more visible levels of quality management. They include an organization's mission and relationship to external environment, the nature of human nature and relationships, and the nature of reality and nature of time. An integrated set of mutually compatible basic assumptions forms quality culture, which is considered to be the theoretical foundation of quality management. In practice, the implementation of a successful quality management program requires a change in organizational culture to be compatible with quality culture. Theoretical analysis and development of the discipline should focus on understanding the consequences of some superficial assumptions inherent in the discipline, and implementation problems that arise from a mismatch between quality culture and organizational culture.

## **Total quality culture (TQC)**

Modern quality management

The traditional method of quality control made the holding of stocks essential. Pressures to reduce stock holding and their associated costs led to the development of Quality Assurance and Total Quality Management (TQM) as replacements for Classic QC. The emphasis now is to prevent the purchase or production of defective goods in the first place, not to catch them after the event.

It is now appreciated that quality depends on the people and the processes used, not just the materials. Quality and efficiency has been widened, therefore, to cover the entire firm, not just materials and products. The avoidance of faulty production requires that three aspects are efficient:

**Methods** - systems and procedures

**People** - both line and staff functions

**Materials**

All these have to be efficient for a quality outcome. All aspects of a firm's operations have to be examined and improved across the firm.

Businesses do not operate in isolation, but as part of a group of organisations forming the supply chain, which includes suppliers, wholesalers, agents and final customers. So, quality assurance teams must work with all of these groups and organisations to ensure that quality is maintained at all levels. This has led to the movement from traditional quality methods to broader quality approaches and philosophies including:

**Quality Assurance** - procedures as well as products are examined and changed if necessary to ensure/assure customers that products are fit for purpose.

**Total Quality Management (TQM)** - this is the system where the responsibility for quality lies with ALL employees. It commits the organisation to continuous improvement (Kaizen) of all activities relating to the quality of the product and the satisfaction of the customer. TQM is really a culture, as to be effective it requires a change in attitudes.

**Self-checking** - the individual or group responsible for the product or task checks quality all the time, ensuring that the next person in the chain receives a quality product.

**Team working.** Firms work with their suppliers, sometimes even investing money and/or buying shares in them, to ensure that the product purchased is of the desired quality, so needing no checking on delivery; in effect it is pre-checked at the supplier's factory.

Quality has become a team responsibility ensuring a focus on high quality at all times. However, quality is not a static concept. The quality of the competitor products may improve, changing the competitive position so requiring a consistent and on-going process of analysis of the external environment and a commitment to continuous improvement.

### **QUALITY AUDITS**

Quality audit is the process of systematic examination of a quality system carried out by an internal or external quality auditor or an audit team. It is an important part of an organization's quality management system and is a key element in the ISO quality system standard, ISO 9001.

Quality audits are typically performed at predefined time intervals and ensure that the institution has clearly defined internal system monitoring procedures linked to effective action. This can help determine if the organization complies with the defined quality system processes and can involve procedural or results-based assessment criteria.

#### **WHAT IS AUDITING?**

Auditing is defined as the on-site verification activity, such as inspection or examination, of a process or quality system, to ensure compliance to requirements. An audit can apply to an entire organization or might be specific to a function, process, or production step. Some audits have special administrative purposes, such as auditing documents, risk, or performance, or following up on completed corrective actions.

#### **THE THREE DIFFERENT TYPES OF AUDITS**

ISO 19011:2018 defines an audit as a "systematic, independent and documented process for obtaining audit evidence [records, statements of fact or other information which are relevant and verifiable] and evaluating it objectively to determine the extent to which the audit criteria [a set of policies, procedures or requirements] are fulfilled." There are three main types of audits:

**Process audit:** This type of audit verifies that processes are working within established limits. It evaluates an operation or method against predetermined instructions or standards to measure conformance to these standards and the effectiveness of the instructions. A process audit may:

- Check conformance to defined requirements such as time, accuracy, temperature, pressure, composition, responsiveness, amperage, and component mixture.

- Examine the resources (equipment, materials, people) applied to transform the inputs into outputs, the environment, the methods (procedures, instructions) followed, and the measures collected to determine process performance.
- Check the adequacy and effectiveness of the process controls established by procedures, work instructions, flowcharts, and training and process specifications.

**Product audit:** This type of audit is an examination of a particular product or service, such as hardware, processed material, or software, to evaluate whether it conforms to requirements (i.e., specifications, performance standards, and customer requirements).

**System audit:** An audit conducted on a management system. It can be described as a documented activity performed to verify, by examination and evaluation of objective evidence, that applicable elements of the system are appropriate and effective and have been developed, documented, and implemented in accordance and in conjunction with specified requirements.

A quality management system audit evaluates an existing quality management program to determine its conformance to company policies, contract commitments, and regulatory requirements.

Similarly, an environmental system audit examines an environmental management system, a food safety system audit examines a food safety management system, and safety system audits examine the safety management system.

## **UNIT – V**

### **THE ISO 9000 SERIES**

The ISO 9000 family of quality management systems (QMS) is a set of standards that helps organizations ensure they meet customers and other stakeholder needs within statutory and regulatory requirements related to a product or service. ISO 9000 deals with the fundamentals of quality management systems, including the seven quality management principles that underlie the family of standards. ISO 9001 deals with the requirements that organizations wishing to meet the standard must fulfil.

Third-party certification bodies provide independent confirmation that organizations meet the requirements of ISO 9001. Over one million organizations worldwide are independently certified, making ISO 9001 one of the most widely used management tools in the world today. However, the ISO certification process has been criticized [self-published source?] as being wasteful and not being useful for all organizations.

ISO 9000 is defined as a set of international standards on quality management and quality assurance developed to help companies effectively document the quality system elements needed to maintain an efficient quality system. They are not specific to any one industry and can be applied to organizations of any size. ISO 9000 can help a company satisfy its customers, meet regulatory requirements, and achieve continual improvement. It should be considered to be a first step or the base level of a quality system.

#### **ISO 9000:2000**

ISO 9000:2000 refers to the ISO 9000 update released in the year 2000. The ISO 9000:2000 revision had five goals:

1. Meet stakeholder needs
2. Be usable by all sizes of organizations
3. Be usable by all sectors
4. Be simple and clearly understood
5. Connect quality management system to business processes

ISO 9000:2000 was again updated in 2008 and 2015. ISO 9000:2015 is the most current version.

#### **ISO 9000:2015 principles of Quality Management**

The ISO 9000:2015 and ISO 9001:2015 standards are based on seven quality management principles that senior management can apply to promote organizational improvement.



### 1. Customer focus

- Understand the needs of existing and future customers
- Align organizational objectives with customer needs and expectations
- Meet customer requirements
- Measure customer satisfaction
- Manage customer relationships
- Aim to exceed customer expectations
- Learn more about the customer experience and customer satisfaction

### 2. Leadership

- Establish a vision and direction for the organization
- Set challenging goals
- Model organizational values
- Establish trust
- Equip and empower employees
- Recognize employee contributions
- Learn more about leadership

### 3. Engagement of people

- Ensure that people's abilities are used and valued
- Make people accountable
- Enable participation in continual improvement
- Evaluate individual performance
- Enable learning and knowledge sharing
- Enable open discussion of problems and constraints
- Learn more about employee involvement

#### **4. Process approach**

- Manage activities as processes
- Measure the capability of activities
- Identify linkages between activities
- Prioritize improvement opportunities
- Deploy resources effectively
- Learn more about a process view of work and see process analysis tools

#### **5. Improvement**

- Improve organizational performance and capabilities
- Align improvement activities
- Empower people to make improvements
- Measure improvement consistently
- Celebrate improvements
- Learn more about approaches to continual improvement

#### **6. Evidence-based decision making**

- Ensure the accessibility of accurate and reliable data
- Use appropriate methods to analyze data
- Make decisions based on analysis
- Balance data analysis with practical experience
- See tools for decision making

#### **7. Relationship management**

- Identify and select suppliers to manage costs, optimize resources, and create value
- Establish relationships considering both the short and long term
- Share expertise, resources, information, and plans with partners
- Collaborate on improvement and development activities
- Recognize supplier successes
- Learn more about supplier quality and see resources related to managing the supply chain.

### **NEED FOR ISO 9000- ISO 9000-2000 QUALITY SYSTEM**

#### **Basic Requirements of ISO 9001**

1. Procedure to cover all processes in the business
2. Monitoring process to ensure effectiveness
3. Keeping adequate record
4. Defect verification and appropriate correction
5. Regular review of individual processes
6. Facilitating continual improvement



## **Benefits of ISO Registration**

1. Increase in internal quality – reduction of scrap, rework etc
2. Production reliability – measure of breakdowns, time and shift management etc
3. External quality – acceptance by customers, less claims, return of goods
4. Time performance – marketing, delivery, production time etc
5. Cost of poor quality – scraps and rework

## **ISO 9000 Family**

- ISO 9000:2000 QMS – Fundamental and Vocabulary
- Basic QMS
- Guidance document for certification
- Revised in ISO 9000:2005

## ISO 9001:2000 QMS – Requirements

- Design, development and installation
- Customer satisfaction through products and service

## ISO 9004:2000 QMS – Guidelines for Performance

- Continuous improvement
- Enhance the mature system

## **PROCESS OF OBTAINING ISO CERTIFICATION**

What Are the Steps of the ISO Registration Process?

ISO Registration Process:

The ISO Registration Process comes after your company's ISO 9001 audit. The purpose of registering your company is to show that you've met the requirements. And to do this effectively, you will need to follow eight essential steps.

### **1. Finding an ISO 9001 Registrar**

You'll need to begin searching for an ISO registrar during the 2 to 3 months your company is still building its quality system. You can search the ANSI-ASQ National Accreditation Board (ANAB) to select the registrar right for you.

Registrars must meet the requirements of the ISO Accreditation Bodies. These requirements include things such as independence; Registrars cannot consult for instance. This system ensures uniformity in the registration process.

Accreditation Bodies maintain directories of the Registrar organizations that they accredit. These directories are available on their websites. You can normally find these websites by doing a search on the Accreditation Body's name or initials.

A directory of registrars in the U.S. can also be found at the ANSI-ASQ National Accreditation Board website which offers access to a searchable database of accredited registrars in the United States.

In Canada, contact the Standards Council of Canada for a list of registrars. All other countries should consult the accreditation authority or member body for their country. Consult the ISO website for a complete list of ISO Member bodies.

## **2. Selecting an ISO Registrar**

Select a registrar that has experience within the scope category of your specific industry, which you can also find on the ANAB site. Keep in mind accreditation, scheduling issues, fees and comfort level when selecting the registrar right for you.

Registrar qualifications are a key consideration. As you research Registrars you will notice that some appear to be very limited in scope just based on their names. Registrars must be accredited in a particular industrial sector in order for them to be able to certify a company in that sector. Some Registrars are accredited in several if not all sectors; others specialize in certain sectors. The best approach to evaluating a Registrar's qualifications for your industrial sector is to contact the Registrar.

After qualifications, price is always a concern. Be sure to evaluate the total cost including expenses, fees and the cost of surveillance.

Probably as important as price, within limits of course, is the overall experience a client gets with a registrar. Important areas to consider are the interpersonal skills of the auditors; the office support and ability to get questions answered; are the audits a value-added experience, will the Registrar work with you, how flexible are they in adjusting dates – how many weeks notice.

## **3. Creating an ISO Application**

A company and a registrar will agree on the application contract. This is an important step of the ISO Registration Process because it defines the rights and obligations of both parties, and includes liability issues, confidentiality and access rights.

## **4. Conducting a Quality Document Review**

The registrar will require a copy of your quality manual and procedures to verify that all the requirements of the standard are addressed. The ISO

Registration Process is not a quick process, be sure to allow 2-4 weeks in advance for the registrar to fully review all of the necessary documents.

### **5. Determining Pre-assessment Need**

Though optional, this 2-4 week initial review of the system identifies any significant omissions or weaknesses. It saves time and allows the registrar to assess any issues and resolve logistics before the actual assessment audit.

The Pre-assessment is an initial review of your Quality Management System to identify any significant omissions or weaknesses in the system and provide your organization an opportunity to correct any deficiencies before the regular registration assessment is conducted.

### **6. Issuing an ISO Assessment**

During the audit, or physical onsite inspection of procedures in action, the auditors will issue findings if they assess anything that doesn't meet requirements, or nonconformities. The length of this step of the ISO Registration Process will depend on the scope of the audit and the size your organization.

### **7. Completing ISO 9001 Registration**

After all of the findings are put into the ISO audit report and nonconformities are addressed, your company has the option to register as ISO 9001 conformant. You will receive a certificate and can also be listed in a register, which the company can use to publicize its registration and use in advertising.

### **8. Checking with Surveillance Audits**

To ensure that the system is maintained and that changes don't result in deficiencies in the system, registrars perform regular surveillances of the system. Over the three-year period of your certificate, auditors will perform one full and two partial checks of your system.

## **ESSENTIAL STEPS TO ISO CERTIFICATION**

### **How much does it cost?**

The costs for developing and registering a formal management system vary depending on the size and complexity of your organization and your internal processes.

**First**—There are developmental costs, namely the time spent documenting and implementing the system.

**Second**—There are costs associated with training employees to prepare the necessary documents and to plan and conduct effective internal audits.

**Third**—There is the cost of registration, which includes conducting the audit and registering the management system. The cost depends on the number of locations, the scope of work, the number of shifts and so on.

### **1. Develop your management system**

Identify your core or business processes.

Document processes with the involvement of employees.

Review, approve and distribute the documents to those who need access to the information.

### **2. Implement your system**

Ensure procedures are being performed as they are described in your documentation.

Ensure employees are trained properly for the tasks they are performing.

Create effective reporting systems to cover inspection, testing, corrective actions, preventive actions, management review meetings, monitoring of objectives, statistical techniques and so on.

Monitor the effectiveness of your processes through the use of measurable data, where possible.

Review and take action to improve in the areas required.

### **3. Verify that your system is effective**

Conduct the audit and review the processes and system for compliance and effectiveness. Observe, interview people and look at sample records.

Identify and report strengths and weaknesses of the management system.

Take corrective or preventive action as required.

### **4. Register your system**

Select the appropriate auditing body for external registration.

Submit your management system documentation for review to ensure it complies with the applicable standard.

Prepare for review by an external auditor to confirm that the system's requirements are being satisfied and that the management system is implemented effectively.

## **ADVANTAGES OF ISO CERTIFICATION**

### **Benefits of ISO 9001:2008/ISO 9001:2015 to your business**

ISO 9001 aims to provide a practical and workable Quality Management System for improving and monitoring all areas of your business. Achieving the ISO 9001 standard is not about establishing a set of procedures that are complicated and difficult to manage. The aim is to provide a workable management system that is suitable for your organisation. With the right support and the knowledge of your employees, you will end up with a system that will improve all areas of your organisation.

Implementing an effective and robust ISO 9001 Quality Management System (QMS) will help you to focus on the important areas of your business and improve efficiency. The management processes that are established throughout your business will provide a sound foundation, leading to increased productivity and profit. This in turn will improve your customer acquisition and retention.

Some of the main benefits of ISO 9001 certification include:

- Suitable for both small and large organisations
- Better internal management
- Less wastage
- Increase in efficiency, productivity and profit
- Improved customer retention and acquisition
- Consistent outcomes, measured and monitored
- Globally recognised standard
- Compatible with other ISO standards

### **Benefits of ISO 9001 to your customers**

The ISO 9001:2008/ISO 9001:2015 standard is recognised worldwide and your customers will understand the benefits of working with companies that are ISO 9001 certified. In fact, some of your customers will only do business with certified companies because it gives them assurance that your management systems are constantly assessed and approved.

They will know from experience that working with ISO 9001:2008/ISO 9001:2015 certified companies provides many advantages:

- Minimizes mistakes
- Improves reporting and communications

- Better quality products and service
- More reliable production scheduling and delivery
- Standards maintained by annual assessments

### **NEW VERSION OF ISO STANDARDS**

The International Organization for Standardization (ISO) is a worldwide federation of national standards' bodies from more than 140 countries (one from each country). ISO standards are documented quality systems and activities, used as the basis for adoption of uniform quality systems norms for international exchange of goods and services.

In fact, 'ISO' is a word, derived from the Greek word ISO meaning 'equal', which is the root of the prefix 'ISO' that occurs in a host of terms, such as 'isometric' (of equal measure or dimensions) and 'isonomy' (equality of laws, or of people before the law). From 'equal' to 'standard', the line of thinking that led to the choice of 'ISO' as the name of the organization is easy to follow.

The name 'ISO' is used around the world to denote the organization, thus avoiding a plethora of acronyms resulting from the translation of 'International Organization for Standardization' into the different national languages of members, such as, IOS in English, OIN in French, etc. The objectives of ISO 9001:2000 quality management systems for an organization are:

To identify the goals that the organization intends to achieve. Goals may be efficiency and profitability, consistently meeting customer requirements, etc.

- a. To consistently meet customer requirements
- b. To achieve customer satisfaction
- c. To enhance market share
- d. To sustain market share
- e. To improve communications and morale in the organization
- f. To reduce costs and liabilities
- g. To increase confidence in the production system

The organization meeting expectations of various stakeholders, such as, customers, suppliers, shareholders, employees, and the society achieve all these objectives.

## **Contents of ISO 9001:2015**

A fish wholesaler in Tsukiji, Japan, advertising its ISO 9001 certification ISO 9001:2015 Quality management systems — Requirements is a document of approximately 30 pages available from the national standards organization in each country. Only ISO 9001 is directly audited against for third-party assessment purposes.

Contents of ISO 9001:2015 are as follows:

Section 1: Scope

Section 2: Normative references

Section 3: Terms and definitions

Section 4: Context of the organization

Section 5: Leadership

Section 6: Planning

Section 7: Support

Section 8: Operation

Section 9: Performance evaluation

Section 10: Continual Improvement

Essentially, the layout of the standard is similar to the previous ISO 9001:2008 standard in that it follows the Plan, Do, Check, Act cycle in a process-based approach but is now further encouraging this to have risk-based thinking (section 0.3.3 of the introduction). The purpose of the quality objectives is to determine the conformity of the requirements (customers and organizations), facilitate effective deployment and improve the quality management system.

## **Criticisms of ISO 9001 certification**

A common criticism of ISO 9000 and 9001 is the amount of money, time, and paperwork required for a complete implementation of the ISO 9001 certification. Dalglish cites the "inordinate and often unnecessary paperwork burden" of ISO, and says that "quality managers feel that ISO's overhead and paperwork are excessive and extremely inefficient". The level of minimum documentation for a minimum scope organization has been greatly reduced, going from ISO 9001:2000 to ISO 9001:2008 to ISO 9001:2015.

According to Barnes, "Opponents claim that it is only for documentation. Proponents believe that if a company has documented its quality systems, then most of the paperwork has already been completed". Wilson suggests that ISO standards "elevate inspection of the correct procedures over broader aspects of quality", and therefore, "the workplace becomes oppressive and quality is not improved".

One study showing reasons for not adopting this standard include the risks and uncertainty of not knowing if there are direct relationships to improved quality, and what kind and how many resources will be needed. Additional risks include how much certification will cost, increased bureaucratic processes and risk of poor company image if the certification process fails. According to John Seddon, ISO 9001 promotes specification, control, and procedures rather than understanding and improvement. Wade argues that ISO 9000 is effective as a guideline, but that promoting it as a standard "helps to mislead companies into thinking that certification means better quality, ... [undermining] the need for an organization to set its own quality standards". In short, Wade argues that reliance on the specifications of ISO 9001 does not guarantee a successful quality system.

The standard is seen as especially prone to failure when a company is interested in certification before quality. Certifications are in fact often based on customer contractual requirements rather than a desire to actually improve quality. "If you just want the certificate on the wall, chances are you will create a paper system that doesn't have much to do with the way you actually run your business", said ISO's Roger Frost.

## **DOCUMENTATION**

### **Documentation of Quality Management System**

A quality system is the method used to ensure that the quality level of a product or service is maintained. The system documentation can be viewed as a hierarchy containing four tiers, as shown in the following illustrations:

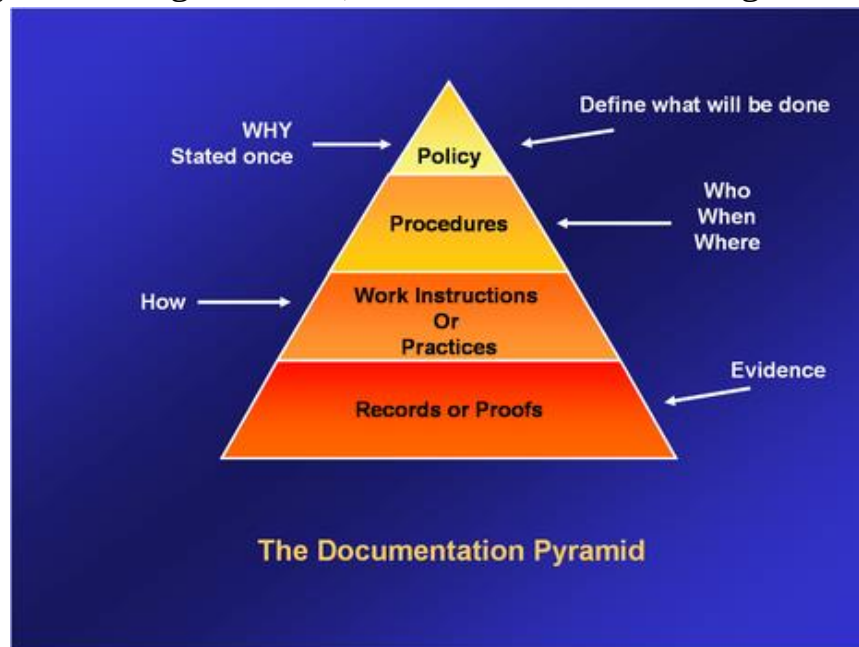



All documentation moves from one level to the next in a descending order. If the system is properly structured, changes at one level will seldom affect the level above it, but may affect those below.

### **Policy**

The first tier of documentation is the policy manual. This is the document that defines what will be done and why. A quality policy manual should be written so it is clear, precise and practical, and easy to understand. The why can be stated just once as a quality policy statement. This statement should be a short, simple definition of the organization's quality intentions. For example:

Quality is the responsibility of each Tempest employee. We pledge to continuously provide products and services that meet or exceed customer expectations.

### **Procedures**

The second tier of documentation is quality procedures. These procedures describe the methods that will be used to implement and perform the stated policies. The procedures define who should perform the specific tasks, when the task should be done, and where the documentation will be made showing that task was performed.

They indicate the strategies that will be used to ensure the quality of the system. Procedures are more detailed than policies; whoever, they, too, should be written in a manner that will allow for easy understanding. It should be noted that procedures are not required for all elements. Many organizations combine the policy and procedures into one document. A procedure is needed if its absence would adversely affect the activity.

### **Work Instructions**

Work instructions are usually department, machine, task, or product oriented and spell how a job will be done. The instructions are the most detailed of the documentation hierarchy. A work instruction may be in the form of a detailed drawing, recipe, routing sheet, specific job function (for example, turn nut four turns clockwise), photograph, video, or simply a sample for comparison or conformity.

The writing of work instruction is best carried out by the employee who performs the task. This person knows the process and problems encountered in that process. However, a documentation specialist may be needed to do actually

writing. This method also creates a pride of ownership in the document, making it more likely to be carried out. Additionally, employee participation helps to ensure that future improvements will be suggested. Not every task requires a work instruction. For example, you don't need to tell a computer specialist to turn on the PC.

## **Records**

Records are a way of documenting that the policies, procedures, and work instructions have been followed. Records may be forms that are filled out, a stamp of approval on a product, or a signature and date on some type of document, such as routing sheet. Records are used to provide traceability of actions taken on a specific product or batch of products. They provide data for corrective actions and a way of recalling products, if necessary.

### **ISO 14000**

ISO 14000 is a family of standards related to environmental management that exists to help organizations (a) minimize how their operations (processes, etc.) negatively affect the environment (i.e. cause adverse changes to air, water, or land); (b) comply with applicable laws, regulations, and other environmentally oriented requirements; and (c) continually improve in the above.

ISO 14000 is similar to ISO 9000 quality management in that both pertain to the process of how a product is produced, rather than to the product itself. As with ISO 9001, certification is performed by third-party organizations rather than being awarded by ISO directly. The ISO 19011 and ISO 17021 audit standards apply when audits are being performed.

The requirements of ISO 14001 are an integral part of the European Union's Eco-Management and Audit Scheme (EMAS). EMAS's structure and material are more demanding, mainly concerning performance improvement, legal compliance, and reporting duties. The current version of ISO 14001 is ISO 14001:2015, which was published in September 2015.

## **Development of the ISO 14000 series**

The ISO 14000 family includes most notably the ISO 14001 standard, which represents the core set of standards used by organizations for designing and implementing an effective environmental management system (EMS). Other standards in this series include ISO 14004, which gives additional guidelines for a good EMS, and more specialized standards dealing with specific aspects of environmental management. The major objective of the ISO 14000 series of norms is to provide "practical tools for companies and

organizations of all kinds looking to manage their environmental responsibilities."

The ISO 14000 series is based on a voluntary approach to environmental regulation. The series includes the ISO 14001 standard, which provides guidelines for the establishment or improvement of an EMS. The standard shares many common traits with its predecessor, ISO 9000, the international standard of quality management[10], which served as a model for its internal structure[8], and both can be implemented side by side. As with ISO 9000, ISO 14000 acts both as an internal management tool and as a way of demonstrating a company's environmental commitment to its customers and clients.

### **ISO 14001 standard**

ISO 14001 defines criteria for an EMS. It does not state requirements for environmental performance but rather maps out a framework that a company or organization can follow to set up an effective EMS. It can be used by any organization that wants to improve resource efficiency, reduce waste, and reduce costs. Using ISO 14001 can provide assurance to company management and employees as well as external stakeholders that environmental impact is being measured and improved. ISO 14001 can also be integrated with other management functions and assists companies in meeting their environmental and economic goals.

ISO 14001 is known as a generic management system standard, meaning that it is relevant to any organization seeking to improve and manage resources more effectively. This includes:

- single-site to large multi-national companies
- high-risk companies to low-risk service organizations
- the manufacturing, process, and service industries, including local governments
- all industry sectors, including public and private sectors
- original equipment manufacturers and their suppliers

## **CONCEPTS AND REQUIREMENTS OF 14000**

### **Plan: Establish objectives and processes required**

Prior to implementing ISO 14001, an initial review or gap analysis of the organization's processes and products is recommended, to assist in identifying all elements of the current operation, and if possible, future operations, that may interact with the environment, termed "environmental aspects". Environmental aspects can include both direct, such as those used during

manufacturing, and indirect, such as raw materials. This review assists the organization in establishing their environmental objectives, goals, and targets (which should ideally be measurable); helps with the development of control and management procedures and processes; and serves to highlight any relevant legal requirement, which can then be built into the policy.

#### **Do: Implement the processes**

During this stage, the organization identifies the resources required and works out those members of the organization responsible for the EMS' implementation and control. This includes establishing procedures and processes, although only one documented procedure is specifically related to operational control. Other procedures are required to foster better management control over elements such as documentation control, emergency preparedness and response, and the education of employees, to ensure that they can competently implement the necessary processes and record results. Communication and participation across all levels of the organization, especially top management, is a vital part of the implementation phase, with the effectiveness of the EMS being dependent on active involvement from all employees.

#### **Check: Measure and monitor the processes and report results**

During the "check" stage, performance is monitored and periodically measured to ensure that the organization's environmental targets and objectives are being met. In addition, internal audits are conducted at planned intervals to ascertain whether the EMS meets the user's expectations and whether the processes and procedures are being adequately maintained and monitored.

#### **Act: Take action to improve performance of EMS based on results**

After the checking stage, a management review is conducted to ensure that the objectives of the EMS are being met, the extent to which they are being met, and that communications are being appropriately managed. Additionally, the review evaluates changing circumstances, such as legal requirements, in order to make recommendations for further improvement of the system. These recommendations are incorporated through continual improvement: plans are renewed or new plans are made, and the EMS moves forward.

#### **Continual Improvement Process (CI)**

ISO 14001 encourages a company to continually improve its environmental performance. Apart from the obvious – the reduction in actual and possible negative environmental impacts – this is achieved in three ways:

- **Expansion:** Business areas increasingly get covered by the implemented EMS.
- **Enrichment:** Activities, products, processes, emissions, resources, etc. increasingly get managed by the implemented EMS.
- **Upgrading:** The structural and organizational framework of the EMS, as well as an accumulation of knowledge in dealing with business-environmental issues, is improved.

Overall, the CI concept expects the organization to gradually move away from merely operational environmental measures towards a more strategic approach on how to deal with environmental challenges.

### **BENEFITS OF ISO 14000**

ISO 14001 was developed primarily to assist companies with a framework for better management control, which can result in reducing their environmental impact. In addition to improvements in performance, organizations can reap a number of economic benefits, including higher conformance with legislative and regulatory requirements by adopting the ISO standard. By minimizing the risk of regulatory and environmental liability fines and improving an organization's efficiency, benefits can include a reduction in waste, consumption of resources, and operating costs. Secondly, as an internationally recognized standard, businesses operating in multiple locations across the globe can leverage their conformance to ISO 14001, eliminating the need for multiple registrations or certifications. Thirdly, there has been a push in the last decade by consumers for companies to adopt better internal controls, making the incorporation of ISO 14001 a smart approach for the long-term viability of businesses.

#### **Direct benefits derived from implementing an effective ISO 14000 include:**

- Material savings through more complete product input processing, substitution, and recycling of by-products and waste
- Reduced energy consumption
- Reduced material storage costs
- Reduced costs for emissions, discharges, waste handling, transport and disposal
- Increased process yields
- Reduced insurance rates
- Reduced customer audits
- Reduced environmental liability
- Reduced enforcement fines

### **Intangible ISO 14000 benefits include:**

- Improved corporate image among regulators, customers and the public
- Proof of social responsibility
- Improved employee morale

The benefits of acquiring ISO certification go beyond the satisfaction of doing a good deed. Adhering to the standard may result in better conformance to environmental regulations, greater marketability, better use of resources, higher quality goods and services, increased levels of safety, improved image and increased profits.

The environmental awareness and the documentation that are required by the ISO 14000 standards assist a company in conforming to environmental regulations. This means that a company, by diligently adhering to the standard, is less likely to violate environmental regulations and is always ready for inspection by a regulatory agency. In addition, the certification and documentation may aid a company in acquiring capital, in defending itself during environmental litigation and in receiving insurance or permits.

A wider market for a company's goods and services may result from certification. Many corporations and governments will be looking for suppliers that are ISO 14000 certified in order to maintain their own certification and environment-friendly image. Although the European Union claims that ISO 9000 certification is not required to do business in Europe, that was the message received by many non-European firms and led to the amazing success of that standard. If ISO 14000 is similarly successful, the companies who are already ISO 14000 certified will have an advantage in global markets. Also, producers of consumer goods may find that many consumers not only try to purchase goods from environment-friendly companies, but will spend a little more if they feel they are helping the environment. In order to reap this benefit, a company must make their environmental efforts known through advertising and labeling.

The process analyses that go along with ISO 14000 certification may result in streamlining processes and more efficient use of resources and raw materials and subsequently reduce a company's costs. Finding ways to capture emissions or recycle the products may, in the long run, reduce the amount of raw materials and utilities used. Reducing the amount of potentially dangerous substances in an end product may result in less use of dangerous chemicals in a plant.